

**Redeemer Christian High School  
Course Calendar  
2024 - 2025**



**Devoted to Christ  
Dedicated to Excellence  
Committed to Serve**



---

## Table of Contents

---

|   |           |
|---|-----------|
| <b>INTRODUCTION TO REDEEMER</b>                               | <b>1</b>  |
| Mission Statement   | 1         |
| Core Values   | 1         |
| Brief History   | 1         |
| School Identity   | 1         |
| School Governance, Structure and Profile                      | 2         |
| Staff and Board Members                                       | 5         |
| Staff Code of Conduct   | 6         |
| Student Welfare   | 6         |
| Student Application Process                                   | 6         |
| Tuition Policy and Fees                                       | 7         |
| <b>STUDENT EXPECTATIONS</b>                                   | <b>8</b>  |
| School Cancellation Procedure (Snow Days)                     | 9         |
| Attendance Policy   | 9         |
| Homework  | 9         |
| Student Achievement   | 10        |
| Examination Policy and Procedures                             | 12        |
| Redeemer School Culture                                       | 12        |
| Student Code of Conduct                                       | 13        |
| Important School Rules and Procedures                         | 13        |
| Discipline Policy   | 17        |
| Concussion Policy   | 24        |
| <b>SPECIAL PROGRAMS</b>                                       | <b>25</b> |
| Introduction to Special Production                            | 26        |
| Guidance and Career Education Program                         | 26        |
| Cooperative Education Program                                 | 26        |
| Resource Program  | 28        |
| School Support Services                                       | 28        |
| <b>ACADEMIC PLANNING</b>                                      | <b>29</b> |
| Ontario Secondary School Diploma (OSSD)                       | 30        |
| Community Involvement Activities                              | 31        |
| Ontario Secondary School Literacy Requirement                 | 32        |
| Ontario Secondary School Literacy Course                      | 33        |
| Online Learning Graduation Requirement                        | 33        |
| Redeemer Christian High School Diploma                        | 34        |
| Ontario Secondary School Certificate (OSSC)                   | 36        |
| Ontario Certificate of Accomplishment                         | 36        |
| Policies on Substitutions for Compulsory Courses              | 36        |
| Alternate Ways to Earn Credits                                | 37        |
| RCHS Online Learning Policy                                   | 37        |
| Prior Learning Assessment and Recognition (PLAR)              | 38        |
| Music Credits   | 39        |
| Access to Course Outlines                                     | 40        |
| Ontario Student Record and Transcript Policies and Procedures | 40        |
| Changing Course Types   | 41        |
| Course Change and Drop Policy                                 | 42        |
| Policy for Students on Spare                                  | 42        |
| Procedure for Having Prerequisites Waived                     | 42        |
| Definition of a Credit  | 42        |
| Course Coding System  | 44        |
| Types of Courses Offered at Redeemer                          | 44        |

|   |           |
|---|-----------|
| Arts Program  | 45        |
| Languages Program   | 46        |
| Mathematics Program   | 47        |
| Physical Education Program  | 47        |
| Science Program   | 48        |
| Social Studies Program  | 49        |
| Technology Program  | 50        |
| Course Selection Worksheet  | 52        |
| Course Selection Worksheet  | 53        |
| Preliminary School Calendar 2024-25                                     | 54        |
| Pattern for Alternating Year Courses                                    | 55        |
| Daily Schedule  | 55        |
| <b>COURSE DESCRIPTIONS</b>  | <b>56</b> |
| Descriptions and Prerequisites of Secondary Courses Offered by Redeemer | 57        |
| Course Codes and Titles Index   | 76        |

---

## INTRODUCTION TO REDEEMER

---

### Mission Statement

---

Redeemer itself is a gift given to this generation through the faithful work of many Christians from a variety of church communities and many walks of life. We stand in that long tradition of devotion and we are committed to the mission our forebears established:

*“To provide a community of learning that challenges students to develop disciplined hearts, minds and bodies according to the full measure of Jesus Christ”.*

---

### Core Values

---

#### Devoted to Christ:

- through a community that pursues Christ-likeness and openness to God
- through a community that worships God and prays together
- through a community that values respect, integrity, humour, forgiveness and friendship
- through a community that is enlightened and enriched by God’s revelation in all activities and relationships

#### Dedicated to Excellence:

- through a community that encourages our students to strive for wisdom based on a love of truth and a love of God’s Word
- through a high quality and integrated curriculum stressing a Christian/Biblical world view
- by offering programs selected to develop reasoning and critical thinking, numeracy, literacy and creativity
- by encouraging students to accept their bodies as gifts from the Lord, developing a healthy lifestyle
- through the development of gifts and talents of students with which God has endowed them

#### Committed to Serve:

- by encouraging the students to participate in opportunities to serve God and others
  - through a community that makes opportunities to serve others both within the school and the wider community
- 

### Brief History

---

Redeemer Christian High School was started in September 1974 by a group of educators and parents committed to the principle of faith-based education in a community setting. The school operates as a society and the Board of Directors is elected from within the membership that is primarily composed of parents and supporters of Redeemer. For the first 20 years of its operation the school rented facilities at various locations in Ottawa but in 1997 Redeemer moved to its present location. Redeemer currently serves approximately 200 students in a Grade 9 through 12 program.

---

### School Identity

---

Legal Name of School: Redeemer Christian High School  
Location of Instruction: 82 Colonnade Road North, Ottawa, Ontario, K2E 7L2  
Telephone: (613) 723-9262  
Facsimile: (613) 723-9321  
Website: [www.rchs.on.ca](http://www.rchs.on.ca)  
E-mail: [info@rchs.on.ca](mailto:info@rchs.on.ca)

Redeemer Christian High School is a non-profit charitable organization registered with the Ministry of Consumer and Commercial Relations of Ontario under Ontario Corporation Number 310735.

Redeemer Christian High School is registered with the Ontario Ministry of Education as a private school, number 889067. Redeemer Christian High School is a registered charitable organization with Canada Customs and Revenue Agency and is eligible to issue donation tax receipts under number 13067 2991 RR0001.

Redeemer Christian High School is a member of Edvance, a service organization established in 1952 which provides an organizational umbrella for over more than 75 schools and 12,000 students across Ontario and eastern Canada at the elementary and secondary levels. Edvance supports its member schools with curriculum development and educational, legal and organizational advice ([www.edvance.ca](http://www.edvance.ca)).

Parents can find consumer protection information about Redeemer Christian High School at the Ministry of Consumer and Business Services' website ([www.cbs.gov.on.ca](http://www.cbs.gov.on.ca)) and the telephone information line (416-326-8800 or toll free 1-800-889-9768).

---

## School Governance, Structure and Profile

---

Redeemer is a non-profit legally incorporated organization previously known as the Community for Christian Learning. The Community for Christian Learning was established in 1975 to promote the idea of Christian secondary education in the Ottawa area. It is responsible for electing a Board of Directors which oversees the operation of Redeemer Christian High School along with the principal. Staff members, as well as parents, and all supporters who are in agreement with our Constitution are encouraged to become members of Redeemer Christian High School as a demonstration of support. The cost of membership is \$100 per person annually. The members of Redeemer Christian High School have two meetings each year (in November and in May).

**Board of Directors:** The Board of Directors is responsible for providing the infrastructure and the support which allows the school to accomplish its mission. The Board of Directors is responsible for casting and owning the vision of the school and for setting policies which govern the school's operations. The Board of Directors hires the principal and can appoint committees to support member business. The principal and the board committees are responsible to the Board of Directors, reporting to the board at its monthly meetings.

Under normal circumstances, staff members who wish to communicate with the Board of Directors do so through the principal.

**Principal:** The principal is hired by the Board of Directors to administer board policy in the daily operation of the school. The principal is responsible for staff supervision. The principal serves the Board of Directors in a non-voting, advisory capacity.

**Vice Principals:** Redeemer functions with an administrative team which includes the principal, the vice-principals and other staff leaders. The staff leadership team works under the supervision of the principal and is responsible for assisting the principal in the operations of the school.

**Committees:** Committees at RCHS are of two types, those reporting to the principal or those reporting to The Board of Directors. Those organized by the principal respond to needs arising from the internal operations of the school. Those organized by the board deal with the business of the membership.

**Finance Committee:** The Finance Committee is a committee of the board and is responsible for the acquisition and the dispersal of financial resources required for operating the school.

**Membership Committee:** The Membership Committee is a committee of the board and is responsible for member recruitment and the maintenance of the membership lists as well as the publication of "*The Report*", which is the agenda and committee reports for the two membership meetings.

**Contract Partnership Committee:** The CPC is a joint committee of the board and the staff and is responsible for contractual matters between staff and the Board of Directors. It consists of two staff members, two board members and two members of the school society.

**Human Resources Committee:** The Human Resources Committee is a committee of the board that considers the appointment and dismissal of permanent staff members.

**Property Management Committee:** The Property Management Committee is responsible for the maintenance of the physical plant, the property and the major pieces of equipment which support the delivery of the program. The Property Management Committee also makes recommendations to the principal about expansion and/or alteration of the building.

**Financial Statements:** The financial statements of Redeemer Christian High School are published at semi-annual membership meetings and via semi-annual newsletters to the school's membership. They are available for viewing by the general public in the school office during normal business hours. These statements are reviewed annually by competent and disinterested persons to see that the financial statements accurately reflect the operations of the society and who report their findings to the Board of Directors and the membership.

### **Redeemer and the Wider World**

Our staff members are supported in their professional life by organizations to which they belong and to which Redeemer belongs. The most important ones are:

**Edifide:** Edifide is the professional association responsible for matters relating to teacher professional development and status. It works jointly with Edvance (see below) to develop policies and procedures regarding conflict management, relations between Boards of Directors and teachers (including salary guidelines and recommendations). The Edifide director is qualified to give legal and professional advice to its members. There is an Edifide representative on the Redeemer staff.

**Edvance:** Edvance is a service organization with over 75 member schools. It provides boards with advice and support in a variety of ways and has a very active curriculum development program in which all teachers are invited to participate.

**Ministry of Education:** The MOE is the Ontario government's education arm which develops educational policy in the province. Redeemer complies with Ministry requirements and guidelines allowing us to grant the Ontario Secondary School Diploma. Redeemer is regularly inspected by the Ministry of Education to ensure our compliance.

**Ontario College of Teachers:** The College of Teachers is the provincial governing body for teachers. Redeemer teachers are encouraged to maintain their membership in the College for their own professional status.

**Christian Schools International:** An organization of Reformed Christian schools throughout North America. CSI serves over 475 schools, with a combined enrollment of over 100,000 students. CSI has been serving Christian schools since 1920.

### **Building Code**

Redeemer Christian High School's building was renovated in compliance with the current Ontario Building Code and all modifications to the building have been done with the proper building permits and inspections.

### **Fire Code**

Redeemer Christian High School is inspected by the local fire department for compliance with the Fire Code. The school conducts fire drills at prescribed times to ensure that students are familiar with safe evacuation procedures.

### **Health Protection and Promotion Act**

Redeemer Christian High School operates in compliance with the Health Protection and Promotion Act through its safe school policies and in courses such as physical education and health.

### **Privacy Protection**

In accordance with the federal *Personal Information Protection and Electronic Documents Act* (PIPEDA), Redeemer Christian High School has adopted a policy to govern the collection, use, and disclosure of personal information.

Personal information collected will be used for purposes relating to the operation of the school, by standing committees, fundraising or to assist in planning educational programs for our students. Redeemer will not disclose your personal information to any other organization or individual outside of the school unless you formally request it or when required by law.

If you have any questions regarding the collection, use or retention of our *Policy to Protect Personal Information*, or if you wish to opt out of receiving specific Redeemer communications, you are invited to contact our privacy officer, the school principal, at 613-723-9262 or at [principal@rchs.on.ca](mailto:principal@rchs.on.ca).

---

## **Membership in Redeemer**

---

Redeemer Christian High School is a non-profit organization which promotes Christian education. Membership in Redeemer Christian High School is voluntary and the annual fee is \$100 per person. All supporters of Christian education (including Parents/Guardians) are welcome to become members. Members will enjoy the rights and privileges (voting for board members, being eligible to be a board member, being eligible to be on board committees) that are part of being a member of this association and assume the obligations (attending membership meetings, voting) of membership. If you are interested in becoming a member please contact the membership committee.



## Staff and Board Members

### Administration (Sept. 2024)

J. David Naftel, Principal  
 Dan Kaiser, Vice Principal  
 Matt Heinbuch, Vice-Principal, Director of Admissions  
 Charlene Van Popta, Business Manager  
 Kim Triemstra, Administrative Assistant  
 Linda Welter, Director of Communications

### Board Members

|              |                   |
|--------------|-------------------|
| Marie Cooper | Brian Vlaming     |
| Jen Harwood  | Anil Balamam      |
| Tim Priddle  | Greg Kopczyk      |
| John Plews   | Matthew Verbrugge |

J. David Naftel (non-voting)

### Professional Credentials of Regular Teaching Staff

|                      |   |
|----------------------|---|
| Brad Armishaw        | B.A. Honours, B.Ed., O.C.T.   |
| Anna Dominique       | B.A. Honours, B.Ed., Specialist in French, O.C.T.                                     |
| Jason Grootenboer    | B.A., B.Ed., M. Worldview Studies, C.S.T.C., O.C.T. , Specialist in Special Education |
| Andrew Hamilton      | B.Sc. Honours, B.Ed., O.C.T.  |
| Matt Heinbuch        | B.A. B.Ed., O.C.T, C.S.T.C  |
| Steven Jaspers Fayer | Cert. of Ed., B.C.S., O.C.T., C.S.T.C., Co-op Specialist                              |
| Tristan Käärid       | B.A. B.Ed., O.C.T, C.S.T.C  |
| Daniel Kaiser        | B.Ed., B.Sc. Honours, O.C.T. , C.S.T.C.   |
| Michael Laliberté    | B.Ed., B.P.E. Honours, Science Minor, O.C.T., C.S.T.C.                                |
| J. David Naftel      | B.Ed., B.Sc., O.C.T., C.S.T.C.  |
| Kritsta VandeKuyt    | B.A. Honours, M.A. Education  |
| Ashley Visser        | B.A. Hon., B.Ed., O.C.T., M.Mus., C.S.T.C.  |

*This list was last updated on Feb. 28, 2022*

|          |  |
|----------|--|
| O.C.T.   | Ontario Certified Teacher  |
| C.S.T.C. | Christian School Teachers Certificate  |
| B.C.S.   | Bachelor of Christian Studies, the Redeemer University College equivalent to a bachelor's degree (B.A.) before it was given degree granting status by the Ontario government |
| M.Mus.   | Master of Music  |
| M.A.     | Master of Arts   |
| M.Ed.    | Master of Education  |

## Staff Code of Conduct

---

The staff code of conduct is based on the Christian values and principles upon which Redeemer Christian High School is founded. We believe that the Bible is the authoritative Word of God as confessed in the creeds of the Protestant Churches and therefore provides the standards for all human behaviour. Teachers are always expected to model Christian values and standards in their conduct, including those times when they are not specifically on duty at school.

The values and standards include but are not limited to the following:

- active church participation
- fidelity in marriage, honouring the marriage vows and reserving cohabitation and sexual intimacy for marriage
- provide for the Christian nurture of their own children and ensure that their children attend a Christian elementary school or are home schooled based on a Christian philosophy of education
- refrain from any offences under the criminal code, provincial offences and the Human Rights Code
- refrain from substance abuse (e.g., drugs or alcohol)
- refrain from a homosexual lifestyle

The school shall continue to demonstrate love and compassion to any employee whose conduct appears to breach moral, spiritual or legal standards as set out above. Recognizing the healing power of Christ's redemption, the school shall explore possibilities of reconciliation and restoration. However, if the conduct of the employee is judged to be inconsistent with the established role model behaviour outlined in the Staff Handbook, the Child Welfare Policy or in some other way is contrary to the aims or standards of the school or brings the school into disrepute in the community, such an employee may be disciplined up to and including dismissal for just and reasonable cause.

---

## Student Welfare

---

The board of Redeemer Christian High School has adopted a *Child Welfare Policy*, in compliance with the Child and Family Services act, available at the school office upon request. The Policy outlines responses to inappropriate contact between students and school staff and provides guidelines for reporting suspected cases of physical and/or sexual abuse. All staff and volunteers who will be in regular contact with the students are required to read and acknowledge that they have understood this *Child Welfare Policy*.

**Criminal Records Check:** In addition to the *Child Welfare Policy* all staff and volunteers who will be in regular contact with the students will be required to submit a current criminal record check before service begins.

**Student Safety:** Redeemer Christian High School Administration regularly checks the Public Register of the College of Teachers ([www.oct.ca](http://www.oct.ca)) to ensure that all Redeemer teachers who are members of the College are in good standing or that their status has not been affected by unprofessional or criminal conduct.

---

## Student Application Process

---

**Preamble:** The purpose of the admissions procedure is to facilitate the admission to the Redeemer learning community of those students who would most benefit from Redeemer's program and who most closely fit the spiritual profile of Redeemer's learning culture.

**Process:** Students who wish to apply for admission may do so by filling in the appropriate application forms (available in electronic format, from the school office if you prefer a hard copy, or from the school website). The support documents required to complete the process are indicated on the application form. A non-refundable application fee is charged for all student applications. Incidental student fees are in addition to the tuition fee.

**Application Fee:** a \$250 fee to cover the cost of processing the application. It is a one-time (per family), non-refundable fee to be submitted with the application forms.

Upon receipt of the application forms and support documents, the school office will contact the applicant to arrange a visit between the principal and the applicant and his/her parents/guardians. The purpose of the meeting is for the applicant and the principal to become acquainted and to assess the appropriateness of the application. The principal will arrange consultations with the Guidance Counsellor/Resource Teacher if required.

The principal will decide on the basis of the documentation and the visit. The school office will contact the applicant with the results of the process.

---

## Tuition Policy and Fees

---

### Student Categories

- **Domestic Student:** a student living in Canada with his/her immediate family with Canadian Income.
- **International Student:** a student who is on a study visa, or whose family has no Canadian Income.

### Tuition Fees

- **Domestic Students:** pay the **fee stated as per the current year's tuition pledge form**. The tuition is on a per-family basis, with a reduction of 25% for those families with siblings at a partner Christian Elementary School to Redeemer Christian High School. Payment is due as pledged.
- **International Students:** pay the International Student Fee **as stated on the current year's International Student pledge form**. Full payment is due when the letter of acceptance is issued. For the following year payment is due by June 1<sup>st</sup>.

**Note:** A student, resident or visa, starting after the semester has begun, will not receive a discount because of the late start.

- **Part-time students:** pay the following fees under the guidelines of their resident or visa status (see also #0401 – Finance – Finance Policies and Procedures):
  - 1 course – 1/6 of the maximum annual fee;
  - 2 courses – 1/3 of the maximum annual fee; and
  - 3 courses – 1/2 of the maximum annual fee, i.e. full cost of the semester's tuition.
  - A distance learning course which is accredited towards the Ontario Secondary School Diploma shall count as a regular course.
  - Families of part-time students are exempt from the Family Volunteer Hours Program.

### Other Fees

All students pay a **Student Incidental Fee** of \$200. This money is held in a student account for each student.

Students have the option of using this account to pay for:

- Redeemer T-shirts for Physical Education
- OCS or Winchester bus tickets
- student lock
- Student Council dinners and activities
- lost text or library books
- yearbook
- school photographs
- Redeemer clothing/school uniforms
- student workbooks
- sports/athletics fees

**Intervarsity Athletics Teams:** Students are responsible for some of the costs

# **STUDENT EXPECTATIONS**

## **Redeemer Christian High School Course Calendar 2024 - 2025**



**Devoted to Christ  
Dedicated to Excellence  
Committed to Serve**

---

## School Bus Cancellation Procedure (Snow Days)

---

When the buses are cancelled, the school is closed.

There are two ways you can check to see if the buses are cancelled. You can check:

1. **Email:** We will send notification of any bus cancellations to current parent and student email addresses on our distribution list.
2. **Edsby:** There will be a notice about the bus cancellation in the river of news.

---

## Attendance Policy

---

All students are required to attend school until they are 18 or have obtained an OSSD.

**Record Keeping:** Official attendance is recorded by the main office of the school. In order to ensure the accuracy of our records and to avoid unnecessary calls home, we ask that parents send us an Edsby attendance message, or if that is not possible, call or e-mail the school to notify us if their child will be absent. The school must notify parents/guardians for each child that is absent without notification.

**Learning Skills:** Student attendance in classes is essential to student success in classes. Teachers also keep their own attendance records for the students in their classes. Teachers keep these records in part to monitor the learning skills of their students. Therefore, the attendance of students may be part of learning skills discussions between teachers, parents, and students.

**Extended Discretionary Absences:** From time to time parents may choose to excuse their student from school for various reasons (like family trips) as is their prerogative. Keeping in mind the importance of attendance in class for student achievement, parents need to know that RCHS does not approve of any extended discretionary absences (trips away from school). However, we ask that parents inform the school in advance. It is the school's policy that students missing days for these extended discretionary absences will not be provided work in advance of the trip, but will be asked to keep up with the daily course work through the Edsby learning management system. Students may receive a few days of grace to catch up missing work upon their return. Parents also need to know that extended discretionary absences during days reserved for exams may result in the student receiving zero on missed exams. Please see the section below on exams.

### **School Hours of Operation and Supervision of Students Before and After School:**

Redeemer Christian High School is open and staff will be present in the building from 8:00 AM to 4:00 PM on normal school days.

The following provisions are required to protect both students and staff from situations where one student is left alone with one teacher, a violation of our Child Welfare policy.

1. Supervision, in accordance with the Child Welfare Policy and Procedures, will ordinarily be provided from 8:00 AM to 3:30 PM, Monday to Friday.

Exceptions for After School Activities (eg. Sport team practices)

2. Two staff-approved adults will supervise students involved in an activity until the activity is completed.
3. The school asks that parents do their best to respect the stated end times for practices.

---

## Homework

---

The purpose of homework is to reinforce concepts, skills, and knowledge taught in classes, to extend the learning time and to prepare for the following day's lessons. Homework time is also used to work on longer-term projects. Students are expected to complete the homework within the deadlines defined by the teacher.

Teachers are expected to give adequate notice of deadlines for any assignment, and they are expected to give complete instructions about the expectations for and the purpose of the assignments. Teachers are expected to mark and return assignments and projects within a reasonable time. Students are encouraged to use their planners to organize their time. They may request information from their teachers about the instructions for assignments, deadlines, purpose of the assignments or about anything else that will help them be successful in their work.

---

## Student Achievement

---

**Preamble:** Assessment and Evaluation are important cornerstones of a successful educational enterprise. By clarifying expectations and making clear the assessment, evaluation, and communication of student achievement students, parents/guardians, and teachers can become more effective partners in student learning.

**Assessment and Evaluation:** Redeemer Christian High School's approach to assessment and evaluation is based on the Ontario Ministry of Education's *Growing Success* 2010, document. *Growing Success* articulates the vision the Ministry has for the purpose and structure of assessment and evaluation techniques. There are seven fundamental principles that ensure best practices and procedures of assessment and evaluation by Redeemer Christian High School teachers. Redeemer assessment and evaluations:

1. are fair, transparent, and equitable for all students.
2. support all students, including those with special education needs, those who are learning the language of instruction (English or French), and those who are First Nation, Metis, or Inuit.
3. are carefully planned to relate to the curriculum expectations and learning goals and, as much as possible, to the interests, learning styles and preferences, needs, and experiences of all students.
4. are communicated clearly to students and parents at the beginning of the school year or course and at other appropriate points throughout the school year or course.
5. are ongoing, varied in nature, and administered over a period of time to provide multiple opportunities for students to demonstrate the full range of their learning.
6. provide ongoing descriptive feedback that is clear, specific, meaningful, and timely to support improved learning and achievement.
7. develop students' self-assessment skills to enable them to assess their own learning, set specific goals, and plan next steps for their learning.

Assessment is the process of gathering information that accurately reflects how well a student is achieving the curriculum expectations in a subject or course. The primary purpose of assessment is to improve student learning. Assessment for this purpose is seen as both "assessment for learning" and "assessment as learning". As part of assessment for learning, teachers provide students with descriptive feedback and coaching for improvement. Teachers engage in assessment as learning by helping all students develop their capacity to be independent, autonomous learners who are able to set individual goals, monitor their own progress, determine next steps, and reflect on their thinking and learning. Redeemer Christian High School teachers use evidence from a variety of sources in their assessment. These include formal and informal observations, discussions, conversations, questioning, assignments, projects, portfolios, self-assessments, self-reflections, essays, and tests. Assessment occurs concurrently and seamlessly with instruction. Our courses contain multiple opportunities for students to obtain information about their progress and achievement, and to receive feedback that will help them improve their learning. Students can monitor their own success through the tracking of learning goals and success criteria throughout all courses.

Summative "assessment of learning" activities occur at or near the end of periods of learning. Evidence of student achievement for evaluation is also collected over time from different sources, such as discussions, conversations and observation of the development of the student's learning. Using multiple sources of evidence increases the reliability and validity of this evaluation. The evaluations are expressed as a percentage based upon the levels of achievement.

The previous terminology for assessment and evaluation used by Redeemer Christian High School was revised with *Growing Success*. The terms *formative*, *summative*, and *diagnostic*, are no longer used; *Assessment For*, *Of*, and *As Learning* delineate the various methods and purposes behind assessment and evaluation. For a full explanation, please refer to *Growing Success*.

For a more detailed explanation of assessment and evaluation at Redeemer please refer to the *Student Assessment and Evaluation Policy*.

Grading of term work is based on student achievement of the expectations in the course outlines. The final mark will be based on term work and on a final project in a 70%: 30% split.

Seventy percent of the grade will be based on assessments conducted throughout the course. This portion of the grade should reflect the student’s most consistent level of achievement throughout the course, although special consideration should be given to more recent evidence of achievement.

Thirty percent of the grade will be based on a final evaluation in the form of an examination, performance, essay and/or other method of evaluation suitable to the course content and administered towards the end of the course. The following table provides a summary description of achievement in each percentage grade range and corresponding level of achievement:

| Grade Range | Achievement 1 | Summary Description   |
|-------------|---------------|---|
| 80 - 100%   | Level 4       | A very high to outstanding level of achievement. Achievement is above the provincial standard.  |
| 70 - 79%    | Level 3       | A high level of achievement. Achievement is at the provincial standard.                         |
| 60 - 69%    | Level 2       | A moderate level of achievement. Achievement is below, but approaching the provincial standard. |
| 50 - 59 %   | Level 1       | A passable level of achievement. Achievement is below the provincial standard.                  |
| Below 50%   |               | Insufficient achievement of curriculum expectations. A credit will not be granted.              |

Level 3 (70 - 79%) is the provincial standard. Teachers and parents can be confident that students who are achieving at level 3 are well prepared for work in the next grade or the next course.

### Determining Student Achievement

- Teachers will make clear, at the beginning of their courses which instruments will count as assessment of student learning and will thus contribute to their grade. This will be done at the beginning of a course in a course syllabus.
- Teachers will, as part of their unit plan, outline the assessment strategies (as, for) they will use to provide feedback to students in preparation for the assessments of student learning.
- Grades will be based on a determination of a level of achievement based on the Achievement Chart. However, late assignments will be dealt with according to the Redeemer Late Assignments Policy.

### Reporting Student Achievement

- Teachers will issue **Progress Reports** for those students about whose progress we are concerned.
- Four weeks after the beginning of the semester, all students will receive an **“Early Bird Report”** in each course which will give parents/guardians and students an early indication of encouragement or concern.
- All students will receive a **Midterm Report** which will summarize the achievement based on the evaluation pieces completed to the middle of the semester. The achievement is reported in an overall

percentage mark based on the levels of achievement. Teachers will report on the Learning Skills demonstrated by the student using the five categories indicated on the report card.

- All students will receive a **Final Report** which will summarize the achievement based on the work of the semester (70%) and the final evaluation piece (30%). Level of achievement will be reported in a percentage mark.
- For both the Midterm Report and the Final Report we use the standard Ontario Provincial Report Card.

---

## Examination Policy and Procedures

---

It is the expectation that all courses taught at Redeemer (except for Physical Education, Drama, and some Art and Technology courses) will have a final exam as part of their 30% summative evaluation at the end of the course. Writing exams is an important academic skill for all students. Writing exams is also the best way for students to demonstrate their acquisition of the course expectations without outside consultation or supports. Some courses may include a final project as part of the 30% summative evaluation along with the exam, which is in line with the Ontario Ministry of Education. This information will be included on the course syllabus.

A five-day block at the end of each semester is reserved for these exams to be written. **Students are expected to write their exams during the scheduled times unless an unforeseen exceptional event such as an illness or family crisis arises. Students requiring alternative dates for exams due to illness or other emergencies should contact the office as soon as they know they have a problem which makes it impossible for them to write their exams. The exam will be rescheduled for a later date.**

Students requiring special arrangements for exam writing due to learning needs indicated on an IEP must work with the Resource Teacher.

The exams will be between one to three hours long as is appropriate for the course.

---

## Redeemer School Culture

---

A positive school climate affects everyone associated with the school: students, staff, parents, and the community. A positive school climate is a crucial component in the promotion of positive behaviour and the prevention of negative behaviour. It is the belief system or culture that underlies the day-to-day operation of a school.

A positive school climate exists when all students feel valued, accepted, and secure in an environment where they can interact with caring people they trust and where everyone actively promotes positive behaviours and interactions.<sup>1</sup> It is when we see Jesus' command to "Love each other as I have loved you."<sup>2</sup> acted out in practical ways in the interactions throughout the school community. It is when our interactions show that Jesus is at the centre in both words and actions, when we see the fruit of the Spirit modelled daily: "Love is patient, love is kind. It does not envy, it does not boast, it is not proud. It is not rude, it is not self-seeking, it is not easily angered, it keeps no record of wrongs. Love does not delight in evil but rejoices with the truth. It always protects, always trusts, always hopes, always perseveres."<sup>3</sup>

Christian principles of respect, justice and compassion are embedded in the learning environment to support a positive school climate. As leaders, educators play an important role in modelling positive, restorative and respectful language and behaviour in schools and classrooms.<sup>4</sup> Student leaders are powerful role models and are encouraged and given opportunities and support to develop good leadership and conflict management skills.

---

<sup>1</sup> Rom. 13:8-10, Phil. 2:1-4, 1Thes. 5:11

<sup>2</sup> Jn. 15:12,17, Jn. 13: 34, Matt. 22:39, Mk. 12:31,33, Lk. 10:27, Ro. 13:9, Gal. 5:14

<sup>3</sup> I Cor. 13:4-7, Gal.5:22

<sup>4</sup> Gal. 6:1-2,



---

## Student Code of Conduct

---

Redeemer has a clearly defined code of conduct, the *Redeemer School Covenant* which all students sign as part of the admissions process, and a clear procedure for responding to unacceptable behaviour, the Redeemer Discipline Policy. In the discipline policy, unacceptable behaviours are divided into Category One, Category Two, and Category Three behaviours. Category One infractions are defined as relatively low risk behaviours, which are inappropriate to a Christian learning environment, and disruptive to the learning environment we are trying to create. Our response to Category One behaviours includes a six-step response system that begins with communication with student and parents and may end with a motion for expulsion by the Principal to the Board of Directors if the student persists in the behaviour. Category Two behaviour is defined as higher risk to the students, the staff and the facilities. The responses include a three-step process and may include suspension and expulsion, depending on the nature of the offence. Category Three behaviours are high risk and seriously damaging to the learning environment; the responses include immediate suspension and expulsion. In general, the emphasis is on correction and restitution so that relationships may be restored, and the student may continue to learn effectively.

---

## Important School Rules and Procedures

---

### Absent Students:

- Students should stay home from school if they feel sick! Students at home should be able to keep up to date with class requirements through the Edsby class pages.
- When a student is going to be absent from school, parents/guardians are expected to notify the school before 8:40 a.m. Parents can report a student's absence from school directly into Edsby.
- The parents will communicate if the student's absence is regarding:
  - a. Illness or
  - b. Another reason
- If the school is not notified of the student's absence by parents, the office staff will call the parent/guardian.

### Coming Late:

- All students who arrive at school late should enter through the main front entrance. When buzzed in, they should report immediately to the office.
- They will then be given a late slip. Then, they can go to their locker and report to class.

### Leaving Early:

- When a student needs to leave school early, the parents should notify the office so that the teachers can be informed.
- After leaving class, students should report to the office to sign out then go outside to be picked up by their parents.

### Parking and Pick-up:

- Parents should not park cars at the front of the building from 8:20 to 8:40 am and from 2:45 to 3:05 pm to avoid blocking or being blocked in by the school busses.
- If they remain in the vehicle, parents/guardians may park along the side of the building. Be mindful not to block this fire lane.

### Chapels/School Meetings:

- Chapel is a mandatory activity; everyone is expected to be there on time.
- Students and teachers will sit with their **homerooms** in their assigned rows.
- Chapels usually involve people in front of the whole school leading various activities. These leaders could be teachers, students, special groups or guest speakers. We are all expected to be respectful.

**Student Account Use:**

- Students may not borrow money from the office or take cash from their student account.
- The student account will only have funds deducted from it for school approved expenses, things like, field trips, student council/school-sponsored dinners, gym clothing, student locks and workbooks.
- At the end of the school year, the balance in a Student Account will be transferred to next year's Student Account or refunded if the family is not returning.
- To eliminate all cash use, students (only with parental permission) will be able to use their student ID card to purchase items at school.

**Sick or Injured Students at School:**

- All **prescription medications** that students need to take while at school must be stored in the office. Students will report to the office to receive their medicine.
- A student who begins to feel sick or sustain an injury at school should report, if able, to the nearest teacher who will give the student further direction.
- The school has a variety of basic first aid kits for fixing minor injuries like paper cuts. Teachers attending to an injured student will wear appropriate personal protective equipment.
- If a student at school develops any symptoms of illness, they will be put in the school's health room until their parents can pick them up.
- Sick students will not be allowed to travel home by bus or by carpool.
- Students who feel unwell, but not sickness related, or who are injured and cannot continue in class will be monitored in the health room in the office until their parents come to pick them up.
- Whenever a student is injured, sick or unwell at school, the parents will be contacted as appropriate.

**Lockers:**

Students should remember that the lockers belong to the school. They are only being borrowed. Students are allowed to personalize the inside of their lockers within the guidelines given below. **The school reserves the right to enter and inspect any locker at any time deemed necessary.** There may be locker checks throughout the year.

- There should be no decorations on the outside of the lockers.
- No writing on the lockers.
- No stickers or permanent attachments to the lockers.
- The inside of your locker should be clean and organized so you can find your school equipment quickly between classes.
- Students are advised not to share their locker combinations with others.
- Students are not to enter the locker of another student without permission.
- If lockers are damaged or defaced, students are to inform the office and the student responsible will be asked to pay for the damages or clean the locker.
- Lockers must be left **closed and locked** whenever you are not accessing your school equipment.
- Renters use the building every night. Remember to lock your locker at the end of the day.

**Hallways:**

The appearance of the halls is very important because it creates the first impression of our school for visitors. Therefore the halls must be kept neat and clean and student conduct in the halls be orderly.

- **No running or roughplay in the halls.** (Because this usually results in people being hurt and we want the school to be a safe place for all.)
- Eating is permitted in the hallways between classes and at lunch.
- Garbage should be placed immediately in the appropriate bins provided. Please pay attention to the labels on the bins.
- Students' personal belongings must only be kept in the lockers.

**Classrooms:**

- No eating in classrooms (to reduce garbage and distraction).
- No coats or school bags in class (to reduce clutter).

**Cafeteria:**

- No loitering by the serving counter.
- No students shall enter the kitchen.
- Students eating in the cafeteria are expected to eat in an orderly fashion and clean up their plates and garbage when done.
- Students have the privilege of using small appliances to heat their lunches (microwaves, kettle, etc.). Do not abuse this equipment or the privilege will be revoked.

**Outside:**

RCHS has a good relationship with our neighbours and we want this to continue. Students should remember that the reputation of our school is affected by your behaviour in public.

- No littering on or around the school or our neighbours' property.
- No loitering on our neighbours' property.
- **No climbing the trees.**
- When students are outside on the side field they should be mindful of the proximity of the road beside the field.
- **All grade 9 students are restricted to the school property from when they arrive to when they go home.**

**Prohibited Activities:**

At Redeemer we strive to live together in a community that is based on Christian principles and standards. Our school community should be safe for all students and teachers. Therefore, certain activities are prohibited for Redeemer students. (For more information please refer to the full RCHS discipline policy.)

- Smoking, use of any tobacco products, vaping, drug/marijuana or alcohol use are prohibited for all students of RCHS.
- Students are not to bully, harass or intimidate other students. Instead students should strive to exhibit the Christian ideals of love, grace, patience and forgiveness in all their interactions with others.
- Although not prohibited at Redeemer, romantic relationships can often prove a distraction from students' academic responsibilities. We encourage all relationships in our community to be based on biblical principles. Therefore, any touching of a romantic or intimate nature beyond hand holding is not allowed.

**Personal Electronic Devices Policy Summary:**

Personal Electronic Devices (PEDs) are wireless and/or portable electronic hand-held equipment that include, but are not limited to: phones, smart watches, cameras, PDAs, MP3s, MP4s, headsets, game systems, and i-Pads. This policy will help ensure a safe and productive learning and working environment for all members and guests of the Redeemer Christian High School community.

1. The **use** of PEDs by students is strictly prohibited on school grounds, except that cell phones may be used only after school outside of the building. After 4pm PEDs may be used to text or call from inside the building.
2. **PEDs are to be kept in lockers**, turned off and not used on the school grounds with the exception noted above. To prevent the loss or damage of PEDs, the school strongly recommends to all students that they leave their PEDs at home.
3. Failure to comply with this policy will result in the confiscation of the PED and/or disciplinary action. Redeemer Christian High School assumes no responsibility for the loss, recovery, repair or replacement for any PED brought onto school property.
4. The Principal (or designate) may authorize an individual(s) to use a PED in the school for a specific designated purpose.

**School Uniform/Dress Code:** (see the *Student and Parent Handbook* on [www.rchs.on.ca](http://www.rchs.on.ca) for full dress code policy) Students not meeting dress code will be required to fix the problem before they enter any class. If they do not comply promptly, they will be sent to the office and may be sent home. (See *Discipline Policy*)

A brief **summary** of the uniform policy is included below:

- All school clothing must be worn as designed and approved by Redeemer.

- All students will comply with the dress code throughout the school day, including before and after school, during the lunch hour, and during field trips.
- Clothing must be clean, non-transparent, size-appropriate (i.e., not too tight or too large), and in good repair.
- Clothing should be worn with appropriate undergarments.
- Only a school logo or name is permitted on school uniforms. Advertisements of any kind on school uniforms are prohibited.
- When students are playing intramurals during the activity block, they may wear athletics clothes.

**Special Dress Days:** At the discretion of the administration and with their pre-approval, portions of the dress code may be temporarily suspended for special dress days or certain outings. In these cases, students will be expected to conform to the Redeemer dress code policy. A summary of the policy is as follows:

Students are to dress in a neat and clean fashion. Clothing should demonstrate respect for one's sexuality. Distracting or immodest clothing that is excessively tight, revealing, low, has rips or tears, or reveals undergarments is not acceptable. All articles of clothing bearing suggestive or offensive materials reflecting anti-Christian values are not permissible. All tops must cover the shoulders and have sleeves, and must overlap the waistband of the pants, shorts, or skirts. Non-uniform shorts or skirts must not be higher than just above the knee.

**Compliance/Enforcement:** Mandatory School Uniform implies that all students arrive at school dressed appropriately. Failure to do so shall result in consequences, (see Discipline Policy # 0202 – Part F – Category 2: Inappropriate School Behaviours).

**Computer Use Rules:** The school owns and operates computers for student use. The use of our computers is a privilege (a service offered to students), not a right. Redeemer has the right to protect its computers and can withdraw the privilege of use of its computer equipment if someone uses them inappropriately. **All use of the student computers must be in support of education and research and consistent with the educational objectives of Redeemer.**

- The computers shall not be used to access chat rooms or social networking sites on the internet without the permission of staff.
- The computers shall not be used to play games.
- The network shall not be used for illegal activity (e.g. violating copyright or other contracts, gaining illegal access or entry into other computers).
- Computers shall not be used for financial or commercial gain.
- Users shall not interfere with the proper operation of RCHS computer systems and networks, as well as systems and networks accessible through the Internet.
- Computers or the network shall not be used in such a way that would disrupt the use of the computers by others.
- Users shall not download any files or programs onto RCHS computers without permission from the Administration.
- Users shall not change any system setting in DOS, Windows or other operating system that may be in use at RCHS.
- No user shall vandalize the RCHS computer system. Vandalism is defined as any malicious attempt to harm or destroy a computer and its parts or the data of another user, Internet, or any listed agency, or other network that is connected to the Internet backbone. This includes, but is not limited to, pulling plugs off computers, swinging mice by the tail, turning the power off on someone else's computer, or the uploading or creation of computer viruses.
- Users shall not access any files/data belonging to others.
- Users shall not attempt to bypass the RCHS filtering system.
- Users shall not access pornography or any other inappropriate material.

**Consequences:** Inappropriate computer use will result in the cancellation of access privileges.

---

## Discipline Policy

---

**Preamble:** The mission of Redeemer Christian High School is to *provide a community of learning that challenges students to develop disciplined minds, hearts and bodies according to the full measure of Jesus Christ.*

The discipline policy and related behaviour management strategies at RCHS serve this mission in two ways:

- First, by creating a safe, effective learning environment that enhances relationships and honours Jesus Christ. The discipline policy addresses our sinful nature and identifies behaviours which detract from or threaten the development of our learning community.
- Second, by providing parameters and opportunities for the character development and training of our students recognizing that the teen years are a time of significant development in the character of young people as they move from child to adult.

Therefore, in our responses to inappropriate behaviour we want to signal those behaviours identified as unacceptable must not be allowed to continue and to encourage students to deepen their relationship with Jesus Christ and live lives that are thoroughly aligned with His standards.

The procedures used by staff to interact with students are based on trust within the community. As participants in the *Parent, School and Student Partnership Covenant* (school covenant), students, parents, and teachers should take the commitments seriously and should be focused on meeting their responsibilities as outlined in it. At the same time, we realize that some training and/or counselling may be necessary for some students as they develop their character and discover how to live as part of a Christian community.

Most of the training of students into the school culture resides with the teachers in their classrooms. When the attempts of teachers to guide the students prove ineffective the situation is transferred to the administration which determines whether the student has had ample opportunity to correct the behaviour in which case it may become necessary to re-evaluate the student's commitment to the school's covenant as reflected by their lack of adherence to the school's standard of behaviour.

**Overview:** The RCHS discipline policy classifies unacceptable student behaviours into three categories based on the severity of their effect on the learning environment and the safety of other students. Unacceptable behaviours represent violations of one or more statements in the **school covenant** which students and their parents or guardians sign before enrolment. It is found in the Admission Application "Form B".

For each incident of behaviour in each category the policy outlines the appropriate consequences. After a certain number of incidents in each category the consequence will be student suspension. After a student suspension the student, parents and administration will meet for a re-entry interview.

The counter for the number of behaviour incidents is reset to zero at the beginning of the academic school year for all grades and at the beginning of each semester for grades 9 and 10. This allows grade 9 and 10 students more chances to remedy their behaviour than grade 11 and 12 students before the school resorts to suspension. The school expects grade 11 and 12 students to be more mature in behaviour and attitude than those in grades 9 and 10 and therefore requiring a smaller number of second chances.

**Detentions:** Detention requires the student to report to a designated area of the school during a specified time on a school day typically during an activity block such as lunch break, or recess and remain there for a specified period of time. It is usually imposed consequential to minor infractions such as unexcused lateness to school.

**Suspensions:** Suspended students may not come onto school property or participate in school activities. In the case of an in-school suspension, parents will bring their student directly to the office on the day of the suspension and will pick them up at the end of regular classes at the office. Suspensions may be up to but not exceed five school days. The administration will report suspensions to the staff and the board. Parents and students will be given a written report of the basis for and the terms

of the suspension. Suspensions will usually be followed by a re-entry interview.

By the time in the process where a suspension is required the student has had ample opportunity for training, counsel and second chances or the students' behaviour is severe enough to warrant an immediate suspension. In either case the student's behaviour must change. The emphasis at this point in the process is on protecting the school's learning environment/culture and re-evaluating the student's commitment to the mission of RCHS as outlined in the school covenant.

The purpose of suspending a student is to:

- Convince the student and parents of the seriousness of the situation and of the school's resolve to see changed behaviour. Although a suspension is not usually good for a student academically it may be an important step in the development of character and necessary to encourage changed behaviour.
- Protect the learning community and culture of the school.
- Provide for a time-out for the student and parents to reflect on their continued commitment to the school covenant.

**Re-entry Interview:** At the re-entry interview following a suspension the student's and parent's continued commitment to RCHS will be discussed. Based on these discussions the administration will develop a behaviour plan for the student that will outline the parameters of future discipline responses pertaining to that student. This plan may include revised behaviour expectations for the student, recommendations for academic assistance, recommendations for counselling, an outline of future discipline measures including suspensions, and the threshold of a move for expulsion by the school.

**Expulsions:** Expulsion is the dismissal of a student from attendance at RCHS. Students may not come onto school property, participate in school activities or expect help from school staff for the remainder of the semester. Students may apply for readmission to the school, but the circumstances of the expulsion will be a factor in the interview process.

The administration will recommend to the Board of Directors to expel that student from the school when it deems that the student's commitment to the school covenant is not taken seriously and determines that the student's presence in the school is harmful to the school culture and learning environment.

The recommendation will include the case history, supporting documents and the grounds for the action. The Board Chairperson will call a meeting of the board to consider the recommendation.

Parents, guardians, or other advocates and the student may address the board at the meeting where the motion is discussed. They will withdraw when the board is ready to discuss the motion. The expulsion will take effect upon the decision of the board to support the motion for expulsion. If the board decides not to support the motion an alternative course of action will be developed by the board and the staff.

### **CATEGORY 1: REPETITIVE DISRUPTIVE BEHAVIOURS**

Students who are not taking adequate responsibility for their own learning often manifest this attitude in the classroom as repetitive-disruptive behaviours. Most instances of this kind of behaviour in a class will be handled by the classroom teacher as part of the teacher's normal classroom management duties. The goal of classroom management is to promote and protect a positive learning environment in the classroom for all students.

However, if a student develops a pattern of repeating these behaviours and does not respond to the direction of the classroom teacher to change this pattern, the administration will become involved to provide support for the teacher's efforts to protect the learning environment in that classroom and to encourage the student to take responsibility for their own learning

Category 1 behaviours are student actions, occurring in the classroom setting, that for each individual instance do not pose a major threat to the learning environment in a classroom. However, these behaviours, if repeated

regularly, will interfere with the learning of the student involved and/or disrupt the learning environment in the classroom. These are behaviours such as:

- Speaking out of turn.
- Getting out of seats at inappropriate times.
- Not completing homework.
- Coming to class unprepared.
- Bringing unacceptable items to class (backpacks, electronic devices, etc.).
- Engaging in disruptive activities e.g., passing notes, making faces or noises, etc.

### Category 1 - Discipline Process

The teacher records the occurrences of the student's repetitive-disruptive behaviour and their responses to it on the Repetitive-Disruptive behaviour log form. Teachers should follow the steps and processes outlined on the form. Teachers are expected to base their discipline recommendations on their records of student's behaviours as per the school's classroom practice guidelines.

- **Report 1:** The student has an interview with administration, problem solutions are discussed, student is suspended in school for one class, behaviour log and behaviour report sent home.
- **Report 2:** The student has an interview with administration, problem solutions are discussed, student is suspended in school for three classes, behaviour log and behaviour report sent home along with an official warning that a suspension from school will result if the behaviour does not change.
- **Report 3:** The student has an interview with administration and is suspended for at least one day, parents notified by phone. The student is not allowed re-entry to the school until a reentry interview with administration, parents and student occurs to reassess the continued relationship of the student with the school and commitment to the school covenant and a behaviour change/exit plan is developed.

### CATEGORY 2: INAPPROPRIATE SCHOOL BEHAVIOURS

Category 2 behaviours do not constitute an immediate threat to the student, teachers or property but they do erode the character of the school culture and represent a breach of the **school covenant**. These behaviours are serious enough that they may result in an incident report being issued immediately. This depends on the nature of the incident and the discretion of the reporting teacher. Most category 2 behaviours are not learning or classroom specific but are likely to occur anywhere in the school.

These are behaviours such as:

- **Skipping class:** Skipping is being absent from a class or school activity without valid permission. Each skip will result in an incident report. The consequences are to make up double the time through detentions at the discretion of administration.
- **Recurring lateness:** Students who are late for a class or school activity must report to the office and receive an admit slip before they will be admitted to the activity. Lates fall into three categories as decided by the administration
  - **Excused:** for various reasons like involvement in other school activities some students will be excused by the administration.
  - **Commuting Lates:** Due to inconsistencies involved in car pools and mass transit systems sometimes students may not make it to school on time. Some of these may be unavoidable and are often not under the control of the student who is late. A record of these kind of lates is kept by the administration.
 

*Note:* If a student has four (4) commuting lates in any given month he/she will be given a warning by the administration that commuting arrangements must be adjusted so the pattern does not continue and the parents will be contacted to discuss solutions to the problem. If more of these lates occur, incident reports may be issued at the discretion of the administration.
  - **Unexcused Lates:** all other lates fall in this category. For each late, a student receives a detention in an activity block. If three unexcused lates occur, an incident report will be issued, and each subsequent group of three lates attracts an additional incident report.
- **Rough play:** rough play is dangerous to the students involved, to bystanders and may result in damages to the facilities

- **Dress Code infractions:** Violations of the Dress Code will be recorded, and Incidents Reports may be issued for repeated violation.
- **Inappropriate language:** Students are expected to use language that enhances relationships, the learning environment and honours Jesus Christ. We use words of grace rather than words of abuse. Therefore, all cursing, vulgar language, terms of abuse, racial or sexual put-downs and malicious gossip are not an acceptable part of the environment we want to create at Redeemer.
  - **Note:** Language that threatens, harasses, intimidates or degrades another person will be dealt with according to the RCHS harassment policy or may be interpreted as threats or assaults in the interpretation of administration. In those cases, the incident becomes “**Category Three**” behaviour and will be treated as such.
- **Dishonesty:** Students are expected to be honest in their dealings with each other and with school staff. Trust is essential to a healthy learning environment and problems are much more easily solved if information is shared in a straightforward manner.
- **Plagiarism:** Plagiarism is the presentation of the words or ideas of another person as your own. In academic works the sources of information must be documented according to the standards set out by the teacher who assigned the assignment. Assignments that contain plagiarism will not be marked until they are corrected by the student. The academic consequences of plagiarism are covered in the Plagiarism and Cheating Policy in the Staff Handbook.
- **Inappropriate romantic physical contact:** We encourage the development of healthy relationships which do not distract from the academic and spiritual aims of the school. The guideline for the physical expression of a relationship is based on the distinction between private and public behaviour. Private behaviour in a public place is embarrassing to bystanders and demeaning to the participants. Therefore, any touching of a romantic or intimate nature beyond hand holding is not allowed.
- **Damage to school property:** Appropriate reparations will be made.
- **Disobedience to teachers:** Disobedience to teachers represents a serious threat to the school community. A category 2 incident report will be issued. If the nature of the incident is more serious a category 3 incident report may be issued at the discretion of the teacher and the administration.
- **Inappropriate use of computers:** Incident reports will be issued for misuse of RCHS computer equipment as defined in the RCHS computer use policy.
- **Disrespect to guests of the school:** Disrespect to guests of the school such as volunteers and supply teachers causes significant damage to the school’s reputation. Our students are expected to be polite and respectful to all people in the school, including supply teachers
- **Disrespect for the school’s religious activities:** Disrespect for the school’s religious activities shows disdain for the very essence of what our school is about and is a breach of the **school covenant**. A category 2 incident report will be issued. If the nature of the incident is more serious a category 3 incident report may be issued at the discretion of the administration.
- **Inappropriate behaviour on school buses:** Students are expected to respect and follow the instructions of the school bus driver.

### Category 2 Discipline Process

Any teacher who sees a student involved in these kinds of behaviours will discuss the incident with that student and issue appropriate consequences and/or incident reports.

- **Incident 1:** Student interview with the administration, consequences applied, incident report sent home.
- **Incident 2:** Student interview with the administration, consequences applied, incident report sent home along with an official warning that a suspension from school will result if another incident occurs.
- **Incident 3:** Student has an interview with the administration and is suspended for one day, parents are notified by phone, re-entry interview with VP, Principal, parents and student on return to reassess relationship with school and commitment to the school covenant. A behaviour change/exit plan is developed.

**Note:** Lateness and absence problems will be dealt with directly by the administration.

### CATEGORY 3: SERIOUS AND DANGEROUS BEHAVIOURS



Category three behaviours are more serious and constitute an immediate threat to the school community, the property or the student him/herself. In most circumstances the school's responsibility is limited to behaviour which occurs while the student is under the care of the school. However, there may be circumstances in which the administration may consider behaviour which occurs at times when the student is not under the care of the school. Examples are assaults, drug trafficking or vandalism that has occurred in other places or at other times but which give evidence of attitudes and behaviours that could constitute a threat to the school and its members. In such cases the administration will investigate the incident, will inform the Board of Directors about the incident and will seek the advice of the board members about the advisability of refusing the student admission to the school.

**Note on Trafficking:** Trafficking means the transfer of a substance from one place to another or from one person to another.

### Category Three Behaviours

Category three incidents should be reported immediately to the administration. Depending on the severity of the incident the consequences shall vary from appropriate restitution to suspensions to expulsion from the school. Following any suspension, a re-entry interview will take place with the subsequent development of a behaviour change/exit plan.

**Note:** Instances/allegations of child abuse are dealt with under the school's *Child Welfare Policy*.

### Definitions and Guidelines

#### 1. Bullying

Redeemer Christian High School believes that bullying is a serious issue that has far reaching consequences for the individuals involved and the entire school community. Providing a safe and respectful school community is an essential foundation for student learning and development. In addition to disciplinary responses to bullying and in an attempt to prevent bullying RCHS will engage in strategies to promote a positive, caring and supportive school community as outlined in the "RCHS: Positive School Culture Strategies Plan" (in the course calendar).

**Definition:** Bullying is defined as a form of repeated, persistent and aggressive behaviour directed at an individual or individuals that is intended to cause (or should be known to cause) fear and distress and/or harm to another person's body, feelings, self-esteem or reputation. Bullying occurs in a context where there is a real or perceived power imbalance. (Source: Ministry of Education)

Different forms of bullying can include, for example:

- **Physical** – hitting, shoving, stealing or damaging property
- **Verbal** – name calling, mocking, or making sexist, racist or homophobic comments
- **Social** – excluding others from a group or spreading gossip or rumours about them
- **Electronic** (commonly known as cyberbullying) – spreading rumours and hurtful comments through the use of mobile phones, e-mail, text messaging and social networking sites

**Non-bullying behaviours:** Unfortunately, there are many ways that students engage in socially harmful or hurtful behaviours. Not all of these behaviours are bullying, but all should be and will be dealt with under other sections of the RCHS discipline policy.

Individual incidents of unkindness between students do occur. While they may not meet the definition of bullying (not repetitive) they will be dealt with by teachers according to the RCHS discipline policy. In addition, in order to more easily detect a possible developing pattern of bullying, teachers will report these individual incidents to the administration. These may include threats, gossip, assault, theft which are already covered in category 3 of the RCHS discipline policy.

Sometimes disagreements, arguments, fights, feuds may develop among students. These again may not fall under bullying because they are happening among social equals but will be dealt with by the administration

**Disciplinary Responses to Bullying:** All accusations of bullying should be reported to a staff member of the school. Reports can be made by either the victims or witnesses.

All reports of bullying will be forwarded to the administration which will begin an investigation of the situation within 24 hours of the report being made. This investigation may include:

- interviews with the victims
- interviews with the accused
- interviews with witnesses
- consultations with teachers

If, through the investigation, the administration determines that bullying has been occurring the administration will:

- Communicate the situation to parents of the bullied and the bully, depending on the nature of the situation the administration may communicate the situation to (and consult with) the School Resource Officer (police)
- Seek to bring about **reconciliation** between the bullied and the bully and the school community as deemed appropriate to the situation by the administration
- Provide resources for any **counselling** needed for the bullied and/or the bully
- Administer **disciplinary consequences** as deemed necessary by the administration according to guidelines included below

**Disciplinary Consequences for the bully:** Disciplinary consequences to bullying will to some degree depend on the seriousness of the situation. Based on consultation with the SRO regarding legal dimensions to bullying, some situations may be handled entirely in school whereas other situations may require the involvement of legal authorities. Aside from any legal consequences that may be applied by the authorities, in-school disciplinary consequences are necessary to deter bullies from continuing this behaviour and to let the community know we consider bullying a serious offence.

- **First report of Bullying by a student:** After the investigation, responses will include a three-day suspension, an apology and an attempt at reconciliation.
- **Second report of Bullying by a student:** After the investigation, responses will include a five-day suspension, an apology and an attempt at reconciliation, a recommendation for the bully to seek counselling and a notice that an expulsion may be requested.
- **Third report of Bullying by a student:** After the investigation, a recommendation will be made to the board to expel the bullying student.

## 2. Disrespect to Staff

Successful teaching is based on a productive and safe relationship between teachers and students. One of the essential qualities of this relationship is mutual respect. Teachers must respect students as children of God under their care and students must respect teachers for the wisdom they possess and the authority they carry.

To some degree, determining what constitutes disrespect to a teacher is determined by cultural background, by personal interpretation and the emotional response of the receiver. However, disrespect towards teachers can be evidenced by any sort of personal attack, put down, or rude comments directed towards the teacher.

Each incident of disrespect of a teacher reported will be investigated by the administration and responses will range from apology to suspension and expulsion. Parents/guardians will be notified of each incident and members of the Board will be informed of more serious incidents.

## 3. Assault and Fighting

Assaults include any touching without permission, threatening words or gestures. The administration will investigate any incidents reported and will judge their seriousness. Response will range from apologies to suspension, expulsion and police involvement if the circumstances require it. Parents/guardians, members of the Board will be informed of any incidents

## 4. Vandalism

Our facilities and equipment are gifts from God made available to us through the hard work and sacrifice of His people. We expect an attitude of respect and care from anyone using the facilities and equipment. Vandalism is the intentional damage to school property and can take many forms, some of which are more and some less

serious so a variety of responses are required. The administration will investigate the incident, including law enforcement officials if necessary. Responses will range from apology and restitution to suspension, expulsion and police involvement. Parents/guardians will be informed in most cases and members of the Board will be informed of the more serious cases.

**5. Theft**

Theft represents a significant threat to the trust so essential to the healthy life of a community. There are more and less serious forms of theft so the responses will be modified to meet each case. Responses will range from apology and restitution to suspension and expulsion. Parents/guardians will be informed in each case and the members of the Board will be informed of the more serious cases.

**6. Pornography**

Redeemer Christian High School has taken the position that pornography in all its forms represents a serious threat to the health of the community and its students. Therefore, possession and use of pornography (this includes computer, video and paper forms) on school property or during a school function is prohibited.

- **Possession and Personal Use:** The student is interviewed by the administration. Parents/guardians and members of the Board are notified. The student is suspended for not less than three and not more than five days. The student may request assistance in dealing with addictions. Re-entry interview occurs.
- **Possession for the purposes of trafficking:** The student is interviewed by the administration. Parents/guardians are notified unless law enforcement officials advise against such notification and the administration makes a motion to the Board for the expulsion of the student for the remainder of the semester.

**7. Tobacco Possession for personal use**

The Redeemer community has taken the position that smoking will not be a part of its school life. Therefore, possession and use of tobacco products during school hours or during school functions are prohibited.

- **Incident #1:** The student is interviewed by the administration. Parents/guardians are notified, and the student may request assistance to deal with an addiction problem.
- **Incident #2:** The student is interviewed by the administration. Parents/guardians are notified, and the student is suspended for not less than one day and not more than three days. Re-entry interview occurs. The student may request assistance in dealing with an addiction problem. The members of the Board will be notified.

**8. Tobacco trafficking and possession for the purposes of trafficking**

The student is interviewed by the administration. Parents/guardians are notified, and the student is suspended for not less than three days and not more than five days. Re-entry interview occurs. The members of the Board are notified. The student may request help in dealing with addictions problem.

**9. Vaping**

The use of vaping chambers is a potentially life-threatening behaviour and is widely considered to be associated with drug culture. Therefore, the Redeemer community has taken the position that vaping will not be a part of its school life. Thus, the possession and use of vaping chambers during school hours or during school functions are prohibited.

**Response:** Any vaping chamber found at school will be confiscated permanently, upon the Principal’s discretion the police may be contacted and consulted, and the vaping chamber and its contents will be turned over to the police for testing and/or disposal.

- **Incident #1:** The student is interviewed by the administration and police. Parents/guardians are notified, and the student may request assistance to deal with the addiction problem. The student is suspended for between 3 to 5 days. Re-entry interview occurs. The Board Chairperson will be notified.
- **Incident #2:** The student is interviewed by administration and Police. Parents/guardians are notified and the student, under the discretion of the principal, may be suspended up to 5 days or suspended beyond 5 days with the board’s approval. The Board Chairperson will be notified.

### **10. Possession of alcohol, cannabis (substances illegal for minors) and illegal drugs**

Redeemer Christian High School has taken the position that alcohol, cannabis in any form and illegal drugs represent a serious threat to the health of the community and its students. Therefore possession and use of alcohol, cannabis in any form and illegal drugs at any time or at any place will be deemed to have brought disrepute upon Redeemer Christian High School, of which these individuals are students.

The administration will notify law enforcement officials at any point in situations involving alcohol, cannabis and illegal drugs on school property or during a school function.

- **Possession for personal use:**
  - The administration interviews the student.
  - Parents/guardians and the Board Chairperson are notified. Offenses off school property, not at school functions and not on school time will attract a suspension for not less than three and not more than five days.
  - Offenses on school property, at school functions or on school time will attract a suspension of five days. Law enforcement officials will conduct their investigation. The student may request assistance in dealing with addictions. Re-entry interview occurs.
- **Possession for the Purposes of Trafficking:**
  - The administration interviews the student. Parents/guardians are notified unless law enforcement officials advise against such notification. The administration recommends the student's expulsion for the remainder of the semester or more at the discretion of the Board.

### **11. Weapons Possession**

The student is interviewed by the administration. Parents/guardians are notified unless law enforcement officials advise against such notification. The administration may recommend a 3-5-day suspension or make a motion to the board for the expulsion of the student. In all instances the board chair will be notified.

---

## **Concussion Policy**

---

Redeemer recognizes the increased awareness of concussions and their long-term effects. We are committed to protecting the health and safety of our students.

- As part of a responsible risk management plan, we recommend that parents and students communicate concussion incidents that happen outside of school to RCHS.
- It is imperative that a medical doctor examines someone with a suspected concussion.
- The parents provide a note from a medical doctor indicating that the student has a concussion.
- If a participant is suspected of having a possible concussion, the participant shall not participate in any physical activity until he/she has visited a medical doctor and been given the proper medical clearance.
- A note from a medical doctor should be provided to indicate that the student may participate once again in sports and physical activity.

**Academic Accommodations and Expectations:** Students who are concussed will still be required to meet the learning expectations as outlined in the Ontario Curriculum. The following accommodations may be available to them according to their individual needs.

- Time extensions that fall within the course completion timeline
- Reduced written output as long as learning expectations are met and are able to be assessed
- Reduced workload until ready to resume full academic participation
- Use of assistive technologies for reading and writing
- Quiet environment
- Oral testing and use of a scribe with assessments (if needed)

# **SPECIAL PROGRAMS**

## **Redeemer Christian High School Course Calendar 2024 - 2025**



**Devoted to Christ  
Dedicated to Excellence  
Committed to Serve**

## Introduction to Special Programs

---

At Redeemer we believe that education is important for every student. Every student has been gifted by God in ways that are unique to them, and we strive to present education in a variety of instructional models and with the necessary learning support mechanisms so that all students can develop their gifts and flourish in their education. This section outlines some of the learning support services we have at Redeemer.

---

## Guidance and Career Education Program

---

The guidance and career education program is a vital and integral part of secondary school. Through the program, students will acquire the knowledge and skills they need in order to set and pursue education and career goals, to learn about the gifts and talents that God has given them, and to carry out their Christian responsibilities. The program is delivered through various means, including classroom instruction, completion of the annual education plan, career exploration activities, and individual assistance and short-term counselling.

It is important for you to become familiar with the role of your guidance counsellor. He will be able to offer you:

- **Academic Counselling** - includes course selection and planning, post-secondary program requirements, levels of difficulty and their implications, direct work entry and apprenticeship information
  - **Career Counselling** - provides information on the career development process, career search and course planning
  - **Personal Counselling** - is available to you when you wish to discuss personal and interpersonal problems. Referrals are made to outside agencies when appropriate
- 

## Cooperative Education Program

---

**Rationale:** Students participating in the Co-op program have the unique privilege of learning through experience in the workforce. Co-op puts theory into action and prepares today's youth for the working world. Classroom theory and lessons become practical applications. Co-op students gain insight into the practical applications of classroom work.

**Thematic Statement:** Since the day that God gave Adam and Eve the cultural mandate, people have wrestled with the meaning and purpose of work. This course looks at the role work plays in our society and how Christians ought to participate in that role. It explores the wisdom imparted by Solomon, who said, "Unless the Lord builds the house, the labourers work in vain." Students wrestle with questions such as, "What is Work?" What skills has God given you? How do you think He has called you to use them? What makes work meaningful? What are some of the generic work skills that all people need? Where do I go to find work? How do I apply for a job? Co-op is serving God through the skills He has given every student. They use their gifts for one purpose alone, to worship the Lord.

**Co-op Program Structure:** The cooperative education programs at Redeemer will be structured according to *The Ontario Curriculum, Grades 11 and 12, Cooperative Education, 2018*.

In collaboration with students, subject teachers, and placement supervisors, cooperative education teachers prepare personalized placement learning plans that include a description of the curricular knowledge and skills and the employability skills that students will demonstrate at their placements. Cooperative education teachers also conduct placement learning assessments and evaluate their students' performance in pre-placement, placement, and reflective learning activities. Students share and analyze their placement experiences with their teachers and peers in structured integration sessions.

Cooperative education is education that takes place in cooperation between the student, the school and a place of business. It is largely based on experiential learning.

A cooperative education course must be based on a related course (or courses) from an Ontario curriculum policy document or on a ministry-approved locally developed course in which the student is enrolled or which he or she has successfully completed. The cooperative education course and the related course (or courses) together constitute a student's cooperative education program, designed to suit the student's strengths, interests, and needs and to enhance the student's preparation for the future. (We currently offer a 2-credit co-op placement in the second semester during the afternoon periods.)

Cooperative education courses include a classroom component, comprising pre-placement and integration activities, and a placement component. Students earn cooperative education credits by integrating classroom theory with planned learning experiences in the community to achieve learning based on the curriculum expectations of the related course. Placements should provide students with challenging opportunities to apply and extend the knowledge, practise and refine the skills acquired in the related course, and to demonstrate achievement of placement expectations that reflect current workplace practices and standards.

Cooperative education involves a partnership between education and business, industry, agriculture, labour, or community organizations that includes students, teachers, parents, employers, and placement supervisors. Additional participants may be involved in the case of exceptional students and other students with special needs. Joint planning by these individuals ensures that students are provided with a systematic introduction to career exploration, experiential learning, and career planning.

Students apply to take a cooperative education course during the course selection process. A counselling and interviewing process – conducted by cooperative education teachers in collaboration with guidance counsellors, teacher-advisers, and administrators – determines applicants' suitability for the program. Prior to their placements, students attend structured orientation sessions as part of the classroom component of the program. Student Co-op placements are found in conjunction with the Co-op coordinator, the parents and the student.

Co-operative education is an experiential mode of learning, delivered under the Ministry of Education subject guidelines, that integrates academic study and classroom theory with experiences at the work site. Students are placed in situations outside the classroom where they experience challenging responsibilities and have opportunities to learn by doing. In this way, learning and experience are combined in an educationally beneficial way.

This course can be offered in relation to almost any in-school class that the student has completed or is taking concurrently. The Co-op program requires a certain skill and maturity level and so applicants are screened through a counselling and interview process. Prior to placement in the workplace, students attend structured orientation and pre-placement sessions. During the placement, students participate in a number of in-class integration sessions, encouraging them to reflect on their experiences.

Co-op is a wonderful and exciting way of putting their more theoretical academic training into practical, hands-on, job training experience. By working with others in the local community, students gain an appreciation for the dignity of work and the opportunity to develop skills God has given them. Through the practice of Christian principles in the workplace, students prepare to assume adult roles as self-directed, self-motivated problem solvers. The practical nature of Co-op allows students to put faith into action. It teaches the student the joy of celebrating the gifts God has granted each individual and directs that skill to service in God's kingdom.

**Important Deadline: November 30:** The interview process is completed in the first semester. This interviewing process is to determine the following things:

- The eligibility of the student to participate in the program,
- What work experience the student would like to initiate, and
- The establishment of a plan of action to achieve the goals that are set.

## Resource Program

---

Students who have special challenges in meeting the expectations of the academic program have access to the resource program at Redeemer. Students may gain access to the resource program by a recommendation from the school or through a parental request. Resource program access is determined by the Principal in conjunction with the Resource Teacher. The program includes assessment of needs, development of individual education plans in consultation with parents/guardians and teachers, recommendation for program accommodations including assistance in writing tests and examinations and completing assignments.

---

## School Support Services

---

**School Computers:** Redeemer has computers for student use throughout the school which are networked and are connected to the Internet. Students must sign compliance with the Computer Use Policy. Use of computer resources at Redeemer is a privilege and may be withdrawn (under the computer use and discipline policies) if students misuse the computers. Students are required to supply their own USB stick.

**Library:** The library is open to students for quiet reading and study. Special permission must be granted to use the library outside of regular hours. Computers are restricted to school related use only. Library resources support the Redeemer curriculum as well as provide leisure reading materials. Items are lent out electronically for a period of one month with the possibility of renewal. Any books not returned are charged to the student at replacement cost.

Students may find it helpful to possess an Ottawa Public Library (OPL) card. Redeemer students living outside of the Ottawa area will be assisted to obtain a free OPL card.



# **ACADEMIC PLANNING**

## **Redeemer Christian High School Course Calendar 2024 - 2025**



**Devoted to Christ  
Dedicated to Excellence  
Committed to Serve**

---

## Ontario Secondary School Diploma (OSSD)

---

What you need to earn an OSSD depends on the year you started Grade 9. There are 2 versions:

### 1. If you started Grade 9 in 2023 or in prior years.

**Requirements:** This diploma will be awarded to students who have successfully completed 30 credits including 18 compulsory credits and 12 optional credits. Such credits will be based on the discipline-specific expectations and assessment policies as set out in the provincial curriculum policy documents. Of these 30 credits at least 2 must be online learning credits. In addition, a student must complete the Ontario Secondary School Literacy Requirement and the community involvement requirements.

#### 18 compulsory credits:

|    |  |
|----|--|
| 4  | credits in English (1 credit per grade)*                     |
| 3  | credits in mathematics (at least 1 credit in Grade 11 or 12) |
| 2  | credits in science   |
| 1  | credit in Canadian history (Grade 10)                        |
| 1  | credit in Canadian geography (Grade 9)                       |
| 1  | credit in the arts   |
| 1  | credit in health and physical education                      |
| 1  | credit in French as a second language                        |
| .5 | credit in civics and citizenship                             |
| .5 | credit in career studies                                     |

Plus one credit from each of the following groups:

#### Group 1

|   |  |
|---|--|
| 1 | additional credit in English, or French as a second language**, or Native languages, or First Nations, Metis, and Inuit studies, or classical and international languages, or social sciences and the humanities, or Canadian and world studies, or guidance and career Education, or cooperative education***, or American Sign Language as a second language, or Langue des signes Quebecoise langue seconde |
|---|--|

#### Group 2

|   |   |
|---|---|
| 1 | additional credit in health and physical education, or the arts, or business studies, or French as a second language**, or cooperative education***, or American Sign Language as a second language, or Langue des signes Quebecoise langue seconde |
|---|---|

#### Group 3

|   |   |
|---|---|
| 1 | additional credit in Science (Grade 11 or 12), or technological education, or French as a second language, or computer studies, or cooperative education***, or American Sign Language as a second language, or Langue des signes Quebecoise langue seconde |
|---|---|

In addition to the compulsory credits, students must complete:

|    |   |
|----|---|
| 12 | optional credits<br>40 hours of community involvement activities<br>the provincial literacy requirement |
|----|---|

\* A maximum of 3 credits in English as a second language (ESL) or English literacy development (ELD) may be counted towards the 4 compulsory credits in English, but the fourth must be a credit earned for a grade 12 compulsory course. \*\* A maximum of 2 credits in French as a second language can count as compulsory credits. A maximum of 2 credits in cooperative education can count as compulsory credits. \*\*\* The 12 optional credits may include up to four credits earned through approved dual credit courses.

## 2. If you started Grade 9 in 2024 or in later years.

**Requirements:** This diploma will be awarded to students who have successfully completed 30 credits including 17 compulsory credits and 13 optional credits. Such credits will be based on the discipline-specific expectations and assessment policies as set out in the provincial curriculum policy documents. Of these 30 credits at least 2 must be online learning credits. In addition, a student must complete the Ontario Secondary School Literacy Requirement and the community involvement requirements.

### 17 compulsory credits:

|    |  |
|----|--|
| 4  | credits in English (1 credit per grade)*                     |
| 3  | credits in mathematics (at least 1 credit in Grade 11 or 12) |
| 2  | credits in science   |
| 1  | credit in Canadian history (Grade 10)                        |
| 1  | credit in Canadian geography (Grade 9)                       |
| 1  | credit in the arts   |
| 1  | credit in health and physical education                      |
| 1  | credit in French as a second language                        |
| .5 | credit in civics and citizenship                             |
| .5 | credit in career studies                                     |
| 1  | credit in technological education (Grade 9 or 10)            |

Plus one credit from the STEM-related course group:

### STEM group:

|   |  |
|---|--|
| 1 | business studies<br>computer studies<br>cooperative education<br>mathematics (in addition to the 3 compulsory credits currently required)<br>science (in addition to the 2 compulsory credits currently required)<br>technological education (in addition to the 1 compulsory credit currently required) |
|---|--|

In addition to the compulsory credits, students must complete:

|    |   |
|----|---|
| 13 | optional credits<br>40 hours of community involvement activities<br>the provincial literacy requirement |
|----|---|

\* A maximum of 3 credits in English as a second language (ESL) or English literacy development (ELD) may be counted towards the 4 compulsory credits in English, but the fourth must be a credit earned for a grade 12 compulsory course. \*\* A maximum of 2 credits in French as a second language can count as compulsory credits. A maximum of 2 credits in cooperative education can count as compulsory credits. \*\*\* The 12 optional credits may include up to four credits earned through approved dual credit courses.

---

## Community Involvement Activities

---

As part of the OSSD requirements students must complete a minimum of 40 hours of community involvement activities outside of class hours. These activities may be completed at any time during their years in the secondary school program. Students must have their community involvement approved through the administration of the school (see the lists below).

Community involvement activities may take place in a variety of settings, including businesses, not-for-profit organizations, public sector institutions (including hospitals) and informal settings. Students may not fulfill the requirement through activities that are counted towards a credit (co-operative education and work experience, for example), through paid work or by assuming duties normally performed by a paid employee. The requirement is to be completed outside student normal instructional hours – that is, the activities are to take place in students’ designated lunch hours, after school, on weekends, during school holidays or during specially designated service

projects organized by the school. The Principal will decide whether the student has met the requirements of both the Ministry of Education and the school for these activities.

Parents and students play a major role in this initiative. Organizations or persons supervising the activities must confirm completion of the hours. Documentation attesting to the completion of each activity must be submitted. This documentation must include for each activity, the name of the person or organization receiving the service, the activity performed, the dates and hours, signatures of the student and his or her parents and a signed acknowledgement by the person (or representative of the organization) involved.

#### Procedures

- Students must get a service hours form from the office
- Bring the form with you to the activity and show it to the activity supervisor
- Make sure the information about the activity is filled out, including a signature by the activity supervisor
- Return the completed form to the RCHS office

List of approved activities: The following activities have been approved by the RCHS administration:

- Volunteering at a summer camp;
- Volunteering at a church (nursery, Sunday school, VBS);
- Coaching a community sports team;
- Volunteering at a social service agency (thrift store, shelter, soup kitchen, food bank);
- Volunteering at a school or daycare for an activity during non-school hours;
- Community clean up;

*Note:* Before engaging in an activity not on this list a student/parent must consult the administration for permission.

List of Ineligible activities: An ineligible activity is an activity that:

- Is a requirement of a class or course in which the student is enrolled (e.g., cooperative education portion of a course, job shadowing, work experience);
- Takes place during the time allotted for the instructional program on a school day. However, an activity that takes place during the student's lunch breaks or "spare" periods is permissible;
- Takes place in a logging or mining environment, if the student is under sixteen years of age;
- Takes place in a factory, if the student is under fifteen years of age;
- Takes place in a workplace other than a factory, if the student is under fourteen years of age and is not accompanied by an adult;
- Would normally be performed for wages by a person in the workplace;
- Involves the operation of a vehicle, power tools, or scaffolding;
- Involves the administration of any type or form of medication or medical procedure to other persons;
- Involves handling of substances classed as "designated substances" under the *Occupational Health and Safety Act*;
- Requires the knowledge of a tradesperson whose trade is regulated by the provincial government;
- Involves banking or the handling of securities, or the handling of jewellery, works of art, antiques, or other valuables;
- Consists of duties normally performed in the home (i.e., daily chores) or personal recreational activities;
- Involves activities for a court-ordered program (e.g., community-service program for young offenders, probationary program).

---

## Ontario Secondary School Literacy Requirement

---

The purpose of the *Ontario Secondary School Literacy Test* (OSSLT) is to ensure that students have acquired the essential reading and writing skills that apply to all subject areas in the provincial curriculum up to the end of Grade 9. All students in public and private schools who are working toward an Ontario Secondary School Diploma are required to write the OSSLT in Grade 10. Students who have been eligible to write the OSSLT at least twice and have been unsuccessful at least once, or with the special permission of the principal before the

second opportunity to write the OSSLT are eligible to fulfill the requirement through the Ontario Secondary School Literacy Course (OLC4O). Successful completion of the OSSLT or OLC4O is a graduation requirement. The accommodations granted to exceptional students in their Individual Education Plans may be applied to in writing. There is no limit to the number of times the test may be re-taken.

**Accommodations:** Students who are receiving special education programs and services and who have an Individual Education Plan may receive the accommodations that are set out in the student's IEP.

**Deferrals:** Only students who might benefit from a deferral of the test should be considered. This may include students who have been identified as exceptional and students registered in English as a second language and or, English literacy development courses who have not yet acquired the level of proficiency in English required for successfully completing the test. The Principal determines if a deferral should be granted and the time period for the deferral.

**Exemptions:** Students whose IEP indicates that the student is not working towards the attainment of a secondary school diploma may, with parental consent and approval of the Principal, be exempted from participating in the literacy test.

---

## Ontario Secondary School Literacy Course (OLC4O)

---

In 2003, the ministry developed the *Ontario Secondary School Literacy Course*. Policy requirements for taking the OLC4O course are contained in the curriculum policy document *The Ontario Curriculum: English, The Ontario Secondary School Literacy Course (OSSLC), Grade 12, 2003*. Students who pass the course are considered to have met the literacy graduation requirement.

The reading and writing competencies required by the OSSLT form the instructional and assessment core of the course. The course differs from other courses in that it outlines specific requirements for evaluation in order to ensure alignment with the requirements of the OSSLT.

Accommodations specified in a student's IEP must be available to the student throughout the course. However, because achievement of the expectations in this course represents fulfillment of the literacy requirement for graduation, no modifications of the expectations are permitted.

---

## Online Learning Graduation Requirement

---

Please see the section, *Online Learning Graduation Requirement Exemption at Redeemer Christian High School*, above, which means that all students who graduate from Redeemer Christian High School do not have to meet this requirement to earn their OSSD.

Students are required to earn two online learning credits to graduate from secondary school, beginning with every student who entered Grade 9 in the 2020-21 school year. The graduation requirement is intended to support students in developing familiarity and comfort with learning and working in a fully online environment, as well as developing digital literacy and other important transferable skills that they will need for success after secondary school, including in post-secondary education and the workplace.

### Definition of "online learning" for this graduation requirement

- Online learning credits that count towards the requirement are earned through courses that rely primarily on communication between students and educators through the internet or another digital platform.
- Online learning credits that count do not generally require students to be physically present with one another or with their educator in the school, except where required for:

## Redeemer Course Calendar, 2024-25

- Examinations and other final evaluations
- Occasional meetings with educators and other school staff, and
- Access to internet connectivity, learning devices, or other supports (for example, guidance, special education and mental health and well-being supports, and required initial assessment and in-person learning for English language learners and students of Actualisation linguistique en français (ALF) or Programme d'appui aux nouveaux arrivants (PANA) at their early stages of language acquisition)
- In online learning courses delivered by schools in the publicly funded education system, coursework is teacher-led.
- Students from the same online class may follow different timetables and be from different schools or school boards.
- Students in publicly funded schools complete their online coursework with the support of a certified Ontario educator with whom they communicate, and who provides instruction, ongoing feedback, assessment, evaluation and reporting as needed, including implementing any accommodations and/or modifications identified in the student's Individual Education Plan.

In-person courses that use digital learning tools in a physical classroom do not count towards the online graduation requirement, nor do remote learning courses that rely on a minimum requirement for synchronous learning.

There is one exception: **Up to one** secondary school credit that was completed by students who were in Grade 9 during the province-wide school closures (from April 2021 to June 2021) may be counted towards the graduation requirement, in recognition of the extraordinary circumstances of the COVID-19 pandemic.

Selection of courses should consider future pathways, the ability and interests of the student to learn in a fully online environment and any potential supports that may be needed. Meeting the online learning graduation requirement should not pose a barrier to graduation for students. As with all learning, students taking online courses will have access to the supports they need through their school, (e.g., guidance, nutrition programs, extra-curricular activities and services for English-language learners). If a student in a publicly funded school has an Individual Education Plan, the plan should be shared, when appropriate, with an educator instructing an online course delivered by another publicly funded school board, with the necessary consent.

Check with your local school if you have questions regarding the registration process.

Parents/guardians may choose to opt their children out of the mandatory online learning credits required for graduation. To opt out, a parent/guardian must submit an opt-out form to the school. Students 18 years of age or older, or who are 16 or 17 years of age and have withdrawn from parental control, can also opt out of the graduation requirement by submitting an opt-out form to the school. School boards must also allow for students and parents/guardians to opt back into the online learning graduation requirement should their decision change. Please contact the school for further information on this process.

---

## Redeemer Christian High School Diploma

---

**To earn a Redeemer Christian High School diploma students must complete all the requirements for the OSSD and achieve the following addition requirements.**

**Designated Worldview Studies Courses:** Two central aims of Christian education are: that students would form deeper commitments to God and mature as a Christian in relation to their world, just as the two greatest commandments are to love God and love your neighbour as yourself. This requires the development of a Christian character which, in turn, requires that the students form principles based on a Christian worldview.

The curricula of all courses and the design of the extra-curricular activities at Redeemer are driven by these aims. All courses are planned to fulfill these aims, even while surpassing the academic requirements of the provincial Courses – 34

curriculum. As such, the Redeemer Diploma entails all the requirements of the OSSD (Ontario Secondary School Diploma) *plus* one Christian worldview-focussed course per grade year. These courses are designed to deliver, in their curricula, the essential elements of Christian worldview and focus on applying these foundational ideas to our world. These courses form the core of our Christian Education Program at Redeemer and are **mandatory for all students**. They are:

|          |   |
|----------|---|
| Grade 9  | HRE13, New Testament  |
| Grade 10 | GLC2O, ½ credit, Career Studies and CHV2O, ½ credit, Civics |
| Grade 11 | CHW3M (World History), or HRT3M, or HRF3O (World Religions) |
| Grade 12 | IDC4U or IDC4O  |

These courses must be taken at Redeemer or be equivalent courses, as evaluated by our guidance department, taken at another Christian Schools International (CSI) or Christian Schools Canada (CSC) affiliated high school. For students coming to Redeemer in grade 10 or 11 from other non-CSI or non-CSC schools, substitutions can be made for courses missed (HRE13 and/or GLC2O/CHV2O) from the following list of Redeemer courses.

|   |
|---|
| CGW4U (World Issues: A Geographic Analysis)       |
| HSB4U (Challenge and Change in Society)           |
| HHS4U (Families in Canada)                        |
| CHY4U (World History since the Fifteenth Century) |

Students who enrol at Redeemer are expected to earn a Redeemer Christian High School Diploma. Regardless of whether or not a student earns an RCHS Diploma, all students enrolled are expected to take the mandatory world view course designated for that grade.

**Community Involvement Activities:** As part of the Redeemer Christian High School Diploma students must complete a total of 60 hours of community involvement activities before graduation. The community involvement requirement is designed to develop awareness of and a commitment to a life of service as an integral part of Christian life. (For further information see the Community Involvement section for the OSSD below)

Parents and students play a major role in this initiative. Organizations or persons supervising the activities must confirm completion of the hours. Documentation attesting to the completion of each activity must be submitted. This documentation must include for each activity, the name of the person or organization receiving the service, the activity performed, the dates and hours, signatures of the student and his or her parents and a signed acknowledgement by the person (or representative of the organization) involved.

**Online Learning Graduation Requirement Exemption at Redeemer Christian High School:** Students are typically required to earn two online learning credits to graduate from secondary school (see OSSD below), beginning with every student who entered Grade 9 in the 2020-21 school year. The online learning requirement “is intended to provide every student with access to high-quality online learning opportunities within a modernized education system.” The Ministry has also provided exemption structures for individual students and for private schools. Redeemer Christian High School believes in the use of technology in learning, especially in our increasingly digital world, and integrates digital content and literacy into numerous courses.

However, *Stepping Stones*, published by the Ministry of Children, Community and Social Services in 2012, highlights that support for youth needs to take into account the whole child – their cognitive, social, emotional, and physical development. Redeemer Christian High School’s educational mission believes this whole child development is best supported through in-person learning. Redeemer Christian High School does not offer online courses internally. Occasionally students may choose to enrol in an external online course for their program and Redeemer Christian High School can facilitate those opportunities. The Ministry of Education memorandum from February 1, 2022, indicates that “inspected private schools . . . may exempt all students of the school from the graduation requirement if, in the principal’s opinion, the online learning graduation requirement strongly conflicts with the religious or educational mission of the school and the school holds the Ontario Student Record for each student.” Redeemer Christian High School’s educational mission is to support the whole student within

a Christ-centred learning community; therefore, all students at Redeemer Christian High School are exempted from the mandatory two credit online learning requirement to graduate. This exemption is approved by the Ministry of Education and is indicated in each student's OSR.

---

## Ontario Secondary School Certificate (OSSC)

---

The *Ontario Secondary School Certificate* (OSSC) will be granted, on request, to students who are leaving secondary school upon reaching the age of eighteen without having met the requirements for the *Ontario Secondary School Diploma*. To be granted an OSSC, a student must have earned a minimum of 14 credits, distributed as follows.

- 7 compulsory credit requirements:

| Program Discipline(s)                  | Required # of credits |
|--|-----------------------|
| English                                | 2                     |
| Canadian Geography or Canadian History | 1                     |
| Mathematics                            | 1                     |
| Science                                | 1                     |
| Health and Physical Education          | 1                     |
| Arts or Technological Education        | 1                     |

- 7 optional credits

---

## Ontario Certificate of Accomplishment

---

**Certificate of Accomplishment:** This certificate may be granted, upon request, by the principal to students who are leaving school prior to fulfilling the requirements for an OSSD or OSSC, but who have achieved significant progress in completing personal and educational goals. An Ontario Student Transcript, including the IEP where applicable, will be attached to the certificate.

---

## Policies on Substitutions for Compulsory Courses

---

### Substitution under OS (2016) for Compulsory Courses

**Procedures:** In certain circumstances it may be necessary for students to seek to replace a compulsory course. To meet individual students' needs a principal may replace up to three (3) of the eighteen (18) compulsory courses (or the equivalent in half courses) with courses from the remainder of those that meet the compulsory course requirements.

Parents or adult students may make a request in writing to the principal and the principal will make the final determination based on discussions with the student, parent (where appropriate), guidance counselor and other school staff. The principal will communicate the decision to the student and parent (where appropriate). The principal may also initiate consideration of credit substitution. Credit substitutions will be noted on the student's Ontario Student Transcript.

The following criteria apply:

- Special learning needs as documented on an IEP
- Previously excused or not enrolled in (elementary school) FSL instruction
- Exceptional circumstances



---

## Alternate Ways to Earn Credits

---

In certain circumstances, it may be necessary for students to seek courses outside of programs offered by Redeemer. To meet individual students' needs, there are a number of alternate ways for students to earn credits that are recognized at the discretion of the principal. They are as follows:

- Distance Learning
- Night School
- Summer School
- External Music Credits – (see Music Programs outside the school for credit) more information is available through Guidance office
- Credit Recovery

**Granting of Credit Equivalencies:** Students must have a minimum of 30 credits to earn an OSSD. Students may be granted equivalencies based upon previous successful secondary work. A minimum of four credits must be taken at an Ontario accredited High School in order to be recommended for the OSSD.

**Home School:** Students' accomplishments will be evaluated based upon the course work completed. Samples of course material may be reviewed and there will be an interview with the student applicant. Proficiency tests may be required in order to determine placement. Credits will be granted at the discretion of the principal.

**International Equivalency Credits:** Students' equivalency credits will be based upon previous successful secondary work in the country of origin. Level of education will be reviewed from original documents from international school. In a situation where a country's academic level is not known and the student's proficiency is in question, external evaluation may be required. World Education Services (Ministry recognized) is one source of evaluation.

---

## RCHS Online Learning Policy

---

### Rationale:

Redeemer Christian High School is founded on the idea that Christian education is essential to the proper maturing and discipleship of the children God has blessed us with. Christ is Lord of the whole universe and over every aspect of the creation. This needs to be the foundation of our students' curriculum and they need to do their learning in the context of Christian community.

The purpose of RCCHS is to offer and support this vision of Christian education.

Key tenets of Christian education are:

1. God is creator and Lord of All. Therefore, He is the creator of all truth and knows what is best for all people and the world he created.
2. God has revealed to people his Truth and guidance for us in the bible and in the person of His Son Jesus Christ.

Therefore:

3. It is imperative that Children and youth are given an education that recognizes God's Lordship in all areas of life, conduct and knowledge.
4. This education must be founded on scriptural principles and their application into all areas of knowledge in the curriculum.
5. For this type of education to be achieved it must be delivered by Christian teachers, who are filled with the Holy Spirit, and can provide an authentic Christian perspective in their courses.
6. Christian teachers are also critical to the process of learning because they will see and honour their students as fellow children of God. Christian teachers will care for their students out of God's love and take part in the discipling of the students in their classes.

7. We believe this Christian education also takes place best in person in Christian classroom communities where students and teachers can meet and work together and practice working together in communities based on God's love for each other.

### **Implications for Online Learning at RCHS:**

Based on our belief in Christian Education (as defined above) Redeemer Christian High School does not believe that Online learning formats are a suitable way to deliver Christian Education.

Therefore:

1. RCHS does not offer online learning.
2. RCHS does use an online classroom management and learning system, but only to support our in-class activities.
3. RCHS students are not required to take online learning. Our students are all exempt from the Ontario Ministry of education's online learning graduation requirement.
4. RCHS does not recommend that any of our students take courses through online learning formats because most of these courses are not taught from a Christian Perspective by Christian teachers and do not constitute Christian Education.

### **Response to requests for online learning:**

Redeemer recognizes that from time-to-time, for various reasons, parents may request that their student take on online course as part of their program at RCHS.

Redeemer's response to these requests is to note that Redeemer does not fully support online education as we believe it does not constitute the best vision of Christian education. However, we also acknowledge from a scriptural perspective, that education of their children is primarily the responsibility of the parents. Redeemer works in partnership with parents to support the best interests of the student in their education. Parents may, given certain circumstances with their student, think that taking an online course may be in the best interests of their student. When this is the case parents may make a request to the school for the student to take on online course.

When such a request is made:

1. Parents are strongly encouraged to register their student for the online course with Nimbus Christian Education. (an online Christian school where the courses are taught from a Christian perspective by Christian teachers) As these courses will be most consistent with our vision for Christian Education.
2. Parents will be informed that by signing up with an online school they are making an agreement with that school and are thus subject that that school's schedules and regulations pertaining to the operations of their courses. Thus, the parents will be solely responsible for managing communication and status of the online course with the online school.
3. Parents will pay the fees for the online course to the online school.
4. The in school support that RCHS will offer to students doing online courses will be:
  - A) Students may be given access to a school computer if necessary.
  - B) Students will be provided a supervised location for them to work on their course at the discretion of RCHS.
  - C) Students may consult with the appointed staff member about any content related questions they are having with their course.
5. Finally, parents and students are reminded that for technical and administrative questions regarding the online course they should contact the online school directly.

---

## **Prior Learning Assessment and Recognition (PLAR)**

---

Prior Learning Assessment and Recognition is a formal evaluation and credit granting process whereby students may obtain credits for prior learning. Prior learning includes knowledge and skills that students have acquired in both formal and informal ways outside secondary school. The PLAR process involves two components: equivalency and challenge. Equivalency involves the assessment of credentials from other jurisdictions.

Equivalency credits are granted for placement. Challenges involve the assessment of prior learning for the purpose of granting credit.

**Challenge course eligibility:** Grade 10 - 12 courses from a provincial curriculum document offered by the secondary school within the board.

A maximum of four (4) credits may be granted through the Challenge process with a maximum of two (2) in one subject area.

**The following courses are not eligible for challenge under PLAR:**

- Locally developed courses including Religion courses  
Co-operative education courses
- Courses for which credit has been previously granted (e.g., to improve a course mark) or for which there is significant overlap with a credit previously granted (e.g., academic and applied course at same grade).
- A course where a credit has already been granted in a later grade (e.g., challenge for grade 10 physical education credit when you already have a grade 11 physical education credit)
- A course you have previously completed but a credit was not earned  
ESL/ELD if an English course under OSS or OSIS has been previously earned
- FSL if a French course under OSS or OSIS has been previously earned
- A student with music certificates that are accepted for credit in OS, Appendix 4, are not required to challenge for credit in the appropriate music courses as per Appendix 4

**Note:** A course may be challenged a second time after a reasonable interval and if reasonable evidence exists that additional study and experience in the interval will lead to success.

Students who plan to challenge a credit will be required to meet with the Guidance Counsellor and Principal. Discussion sessions on the PLAR challenge process will be held in September and February of each school year. Following the meeting, students who intend to challenge a course for credit will be required to submit, with the application form, a portfolio containing reasonable evidence of the likelihood of success. Application forms are available from the Guidance Counsellor.

Upon assessment of the evidence provided and approval of the application, a formal, written and practical assessment will constitute 70% of the grade. The remaining 30% of the final mark will involve a variety of assessments appropriate for the course. Through the assessment activities students will be required to demonstrate that they have achieved all expectations of the course they are challenging for credit. Students will have approximately two months in which to complete challenge activities and provide evidence of achievement.

PLAR Challenge assessments must be completed by the end of the semester in which the course has been challenged.

---

## Music Credits

---

The following are the requirements for acceptance of music certificates for credits towards the OSSD.

1. A maximum of one Grade 11 university/college preparation music credit may be awarded towards the OSSD for the successful completion on one of the following:
  - Level VII Practical and Level 6 or Level 7 Theory (formerly Intermediate Rudiments) of the Royal Conservatory of Music, Toronto
  - Grade VII Practical and Grade III Theory of Conservatory Canada, London, Ontario
  - Collegial I Practical and Collegial I Theory of any conservatory of music in the province of Quebec
  - Grade V Practical and Grade III Theory of Trinity College London, England
  - Grade VII Practical and Grade VI Theory of the Royal Schools of Music, London, England
2. A maximum of one Grade 12 university/college preparation music credit may be awarded towards the OSSD for the successful completion of one of the following:

- Level VIII Practical and Level 8 Theory (formerly Advanced Rudiments) of the Royal Conservatory of Music, Toronto
- Grade VIII Practical and Grade IV Theory of Conservatory Canada, London, Ontario
- Collegial II Practical and Collegial II Theory of any conservatory of music in the province of Quebec
- Grade VI Practical and Grade IV Theory of Trinity College, London, England
- Grade VIII Practical and Grade VIII Theory of the Royal Schools of Music, London, England

#### *Notes*

- The term *practical* refers to any musical instrument on which performance is examined. It includes voice (i.e., singing), but not speech arts.
- The mark credited to the student is calculated by averaging the marks that the student has earned in the practical component *and* in rudiments or theory, as the case may be.
- A music credit obtained through a certificate granted by a conservatory of music may not be used to meet the compulsory credit requirement in the arts or the additional compulsory credit requirement outlined for Group 2.
- A student awarded 2 music credits in this manner may not earn additional Grade 10 to 12 music credits through the Prior Learning and Assessment (PLAR) challenge or equivalency process.
- The course titles and course codes for the credits granted under sections 1 and 2 above are as follows:
  - *Section 1: Music – External (Conservatory), AMX3M*
  - *Section 2: Music – External (Conservatory), AMX4M*

---

### Access to Course Outlines

---

Outlines of all courses taught in the school are kept on file and are available to parents on request. Please contact the Vice-Principal at the office if you want to view a course outline.

The complete Ministry of Education Curriculum Documents can be found on [www.edu.gov.on.ca](http://www.edu.gov.on.ca).

---

### Ontario Student Record and Transcript Policies and Procedures

---

**Definition of the *Ontario Student Record (OSR)*:** The OSR is the official record for a student. Every Ontario school keeps an OSR for each student. The OSR contains achievement results, credits earned, diploma requirements completed and other information important to the education of the student. OSRs are maintained according to the Ministry of Education OSR outline.

**Ontario Student Record Policy:** The Education Act states that the principal of a school will collect information “for inclusion in a record in respect of each pupil enrolled in the school and to establish, maintain, retain, transfer and dispose of the record”. This record is contained in the *Ontario Student Record*.

- The records are to be kept in a locked fireproof filing cabinet in the office.
- Only the principal, teachers currently employed at Redeemer Christian High School, and the school secretary will have access to the records.
- The Guidance Department will review each OSR at the end of each academic year.
- A student 18 years of age and older will be allowed to see his/her OSR and the parents/guardians of students under the age of 18 will be allowed to see their child’s OSR. Room will be provided in the office area for viewing. The OSR may not leave the office area.

**The *Ontario Student Transcript and Full Disclosure*:** The *Ontario Student Transcript (OST)* provides a comprehensive record of the credits that a secondary school student has earned towards fulfillment of the requirements for the graduation diploma. This record will include all the credits gained by the student using regular study and correspondence, independent study, private study, continuing education and summer school which are approved by the principal.

The *Ontario Student Transcript* (OST), which is a part of the *Ontario Student Record* (OSR), will include the following information:

- A list of all the grade 9 and 10 credits **achieved** with percentage grades
- A list of all Grade 11 and 12 courses taken or **attempted** by the student, with the percentage grades earned and the credits gained (students repeating a course for which they have already earned a credit will earn only one credit for the completion of that course)
- Identification of any course that has been substituted for one that is a diploma requirement
- Confirmation that the student has completed the community involvement requirement
- Confirmation of successful completion of the *Ontario Secondary School Literacy Requirement*
- An indication of any extraordinary circumstances affecting the student's achievement in a Grade 11 or 12 course

In addition to recording the number of credits earned, Redeemer may indicate on a student's transcript that the student has taken a specialized program.

**Course Withdrawals:** Withdrawal after 5 teaching school days following the issuance of the first provincial report card (mid-semester report) from any grade 11 or 12 course will be recorded on the OST ("W" indication in the "Credit" column). The percentage grade reported will be the grade at the time of withdrawal and will appear in the *Percentage Grade* column. No credit will be granted, as the course has not been completed.

**Exceptional Students:** The OST will also be used to record the achievement of students who have alternative learning expectations in an individualized, non-credit program.

As a result of legislation passed (as of September 1999) all attempts at a senior course (grades 11 or 12) **whether successful or not** will be recorded on the transcript. Repeated courses will be shown on the transcript as well. Both marks will show but only **one** credit will be granted. Courses withdrawn from after 5 teaching days following the first report card (mid-semester report) will be recorded on the OST with the grade at the time of withdrawal.

If a student fails a course, the percentage grade will be entered in the "Percentage Column" and a "0" will be entered in the "Credit" column.

Students who successfully complete any academic or applied course in Grade 9 will have acquired the core knowledge necessary to proceed to either type of course in grade 10. However, some students may be encouraged to successfully complete additional course work. This additional self-directed course work will allow the student to demonstrate the learning expectations that are included in one course type but not the other.

---

## Changing Course Types

---

Some students may change their educational goals as they proceed through secondary school. When they decide to embark on a new pathway, they may find that they have not completed all of the prerequisite courses they need.

In Grades 10 to 12, a student may change to a different type of course in a given subject provided that the student has taken any course specified as a prerequisite for that course. If the student has not done so, he or she may take one of the specified prerequisite courses through summer school, night school, e-learning, the Independent Learning Centre, or independent study.

If the principal believes that a student can be successful in a particular course without having taken the specified prerequisite course, the principal may waive the prerequisite.

## Course Change and Drop Policy

---

Through the process of educational planning, students are encouraged to choose their courses carefully based on their academic ability and progress to date, as well as their tentative destination. Revisions to course selection may be advisable and should be requested by making a guidance appointment to discuss the changes with the guidance counsellor. Advisability and availability of the requested change will be discussed, and course changes will be made only after parent and administrative approval has been received. For a course in progress, requests for a course change should be made within the first ten days of the semester. For changes between levels in any given discipline, the change must be completed within the first four weeks of starting the course. Requests to drop a course will be subject to school policy on dropping courses and the rules of full disclosure will apply. Under the policy of full disclosure which was implemented by the Ministry of Education in September 1999, a senior course which is dropped after five days following the mid-term report will show on the student's transcript as a withdrawn course and a mark at the time of withdrawal will be entered. Consult the guidance department for more information.

---

## Policy for Students on Spare

---

Students in grades 9 through 11 are expected to take eight courses per year. Under **extenuating circumstances** (ie. Special needs students or students transferring from other school systems), students in grades 9 through 11 may be granted approval to take a spare by the administration. See the guidance department for necessary forms and advice.

Grade 12 students on spare are required to be found working in designated study areas (e.g., cafeteria, library, designated classroom). Hallways, stairwells and the front lobby are not considered designated study areas.

---

## Procedure for Having Prerequisites Waived

---

Courses in Grades 10, 11, and 12 may have prerequisites as a requirement for enrolment. All prerequisite courses will be identified in ministry curriculum policy documents, and no courses apart from these may be identified as prerequisites. Redeemer Christian High School provides parents and students with clear and accurate information on prerequisites.

If a parent/guardian requests that a prerequisite be waived, the principal will determine whether or not the prerequisite should be waived. The principal may also initiate consideration of whether a prerequisite should be waived. The principal will make his or her decision in consultation with the parent/guardian and appropriate school staff.

In the case of a prerequisite being waived, a letter, signed by the principal and the parent/guardian confirming approval, is placed in the student's OSR.

---

## Definition of a Credit

---

A credit is earned upon successful completion of a course for which a minimum of 110 hours has been scheduled. A credit is granted to a student by the principal of a secondary school on behalf of the Minister of Education and Training.

**Grade 9 and 10 Courses:** For all students in Grades 9 and 10, four types of courses are offered: Academic, Applied, De-streamed and Open. For students receiving Special Education Support, Redeemer Christian High School offers an additional type of course: Essential.

- **Academic courses** develop students' knowledge and skills through the study of theory and abstract problems. These courses focus on the essential concepts of a subject and explore related concepts as well.

- **Applied courses** focus on essential concepts of a subject and develop students' knowledge and skills through practical applications and concrete examples. Familiar situations are used to illustrate ideas, and students are given more opportunities to experience hands-on applications of the concepts and theories they study.  
**Note:** Students must choose between academic and applied courses in the core subjects; English, French as a Second Language, Mathematics, Science, Geography, and History.
- **De-Streamed courses** are designed to prepare students for further study in a subject while still leaving all future learning pathways open.
- **Open courses** are designed to prepare students for further study in a subject, and to enrich their education generally. Open courses comprise a set of expectations that are appropriate for all students.
- **Essential** - This program is a locally developed credit program designed for students whose Individual Education Plan indicates he/she is working on grade 5-7 expectations from the Ontario Curriculum in Mathematics, Science and/or English. The suitability of these courses is determined at an interview with the Resource teacher in combination with Learning Test Results. Students may also take a Learning Strategies Course to support their learning. These courses are credit bearing, leading to the workplace stream.

**Grade 11 and 12 Courses:** Courses in grades 11 and 12 are designed to prepare students for a post-secondary destination. There are 5 types of courses offered:

- **University Preparation Courses:** These courses are intended to provide students with the knowledge and skills to meet entrance requirements for university programs. Courses focus on theory and also investigate related applications. These courses are also required for entrance into Applied Degree programs at all Community Colleges.
- **University/College Preparation Courses:** These courses are intended to provide students with the knowledge and skills they need to meet the requirements for entrance to selected University programs and most College programs. Courses focus on concrete application of theoretical material.
- **College Preparation Courses:** These courses are intended to provide students with the knowledge and skills they need to meet the requirements for entrance to most College programs or for admission to Apprenticeship or other training programs. Courses focus on concrete application of theoretical material.
- **Workplace Preparation Courses:** These courses are intended to prepare students to move directly into the workplace after secondary school or to be admitted into Apprenticeship programs or other training programs. Courses focus on employability skills and on practical workplace applications.
- **Open Courses:** These courses focus on general skills and knowledge related to both theory and practical application. There is one set of expectations for all students.

---

## Course Coding System

---

Every subject is identified by a common course code designated by the Ministry of Education. The code consists of five characters:

S B I 3 C

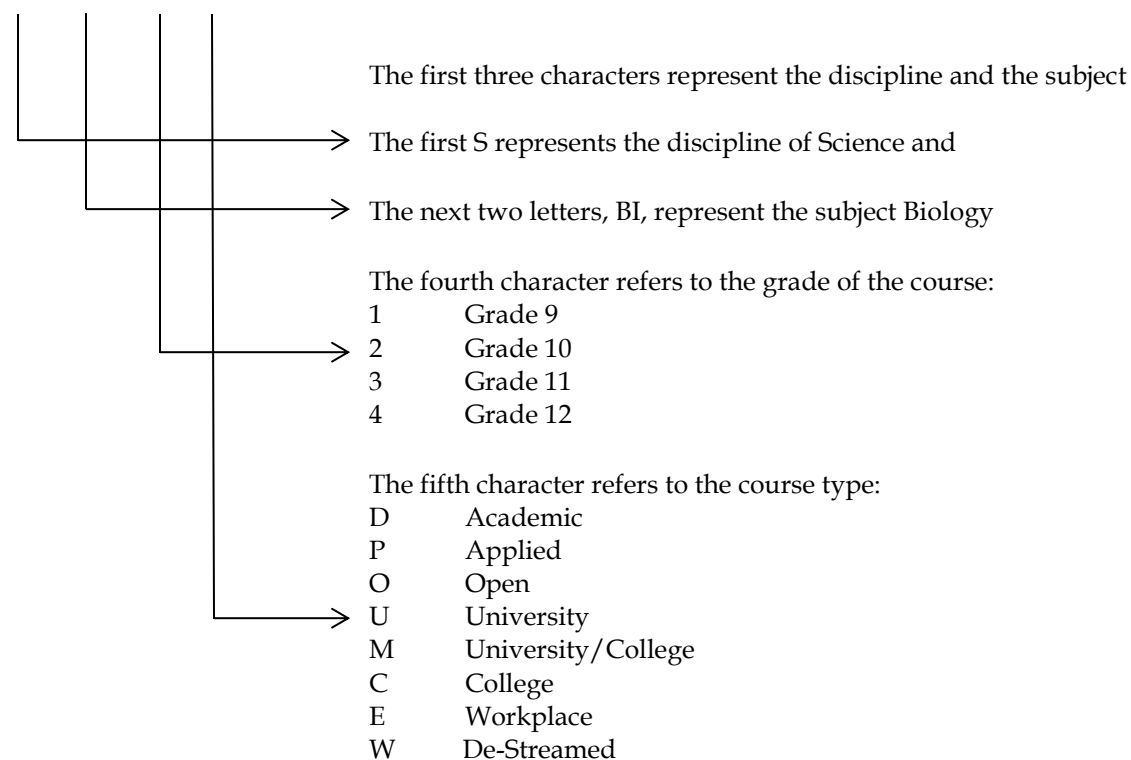

**Other Codes:** There are additional codes (6<sup>th</sup> character) designated by Redeemer for students in specialized programs.

---

## Types of Courses Offered at Redeemer

---

The material presented in our courses can be understood on several levels. On one level, it is material to be learned so that the learners can earn credits toward graduation. On another level, students can gain skills, information, and knowledge which will make them more effective human beings, both in equipping them to reach their own goals, and as members of the human community. At their best, however, our departments are windows on God's world and the courses in the departments are like unique panes of glass which allow us to see God at work in the many ways that continue to astonish, intrigue, exasperate and stretch us. We want to say to our students, "There is more to what you see than what meets your five senses. Look up, listen up and see, hear God. Allow yourself to experience awe and joy as you see Him at work. Allow yourself to be transformed and commit yourself to a life of transformation in His service!" So, we are a real high school, and these are real courses, but they are most fundamentally ways in which we can get to know God, His world and ourselves in His world.

Courses at Redeemer are organized into the following departments:

- Arts
- Languages and Communication
- Social Studies
- Mathematics
- Physical and Life Sciences
- Technology
- Physical Education
- Cooperative Education Program



## Arts Program

The Arts are a valuable and often unique means of communication, expression, experience and understanding. Their great importance lies in their ability to give concrete form and life to ideas, attitudes, emotions, relationships and beliefs. They are able to transcend rational thought and experience; they can reveal what lives inside a person; and they can build skills of discernment and reflection. The Arts are best practiced in the community. By engaging in them, students are able to discover, experience, communicate and express the truth about their relationship with themselves, with others, with the created world and with God.

Participation in the bi-yearly drama production for credit will earn students a half credit in either ADD30 or ADG30.

### Drama



### Visual Arts



### Media Arts

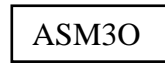

### Music

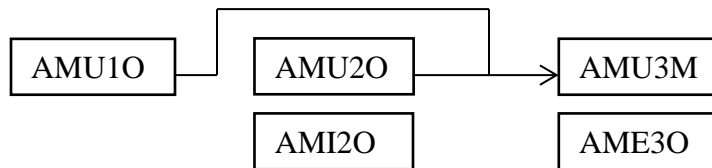

## Languages Program

All Language and Communication courses at Redeemer have several components and are designed to achieve competence in the comprehension of fiction and non-fiction texts and to develop an effective use of language. Since language is the basis for communication, students need to achieve competence in its use and understanding if they are to function effectively as members of their communities and as ambassadors for Christ. Mastery of good communication skills is important for learning in all disciplines and for functioning effectively in all areas of life. Consequently, a well-rounded language and literature program in both French and English is of great importance in the Christian school curriculum.

A Christian approach to communication emphasizes the positive use of language according to the scriptural demand that our speech be trustworthy and up-building. By recognizing this imperative, students can come to appreciate the gift of language and be empowered to praise God and bless their neighbours. By means of a sound language and communication program they will become aware of creative and artistic dimensions of language and they will develop discernment in the negative uses of language in the great literature in the human tradition and the current use of language in the media.

### ENGLISH

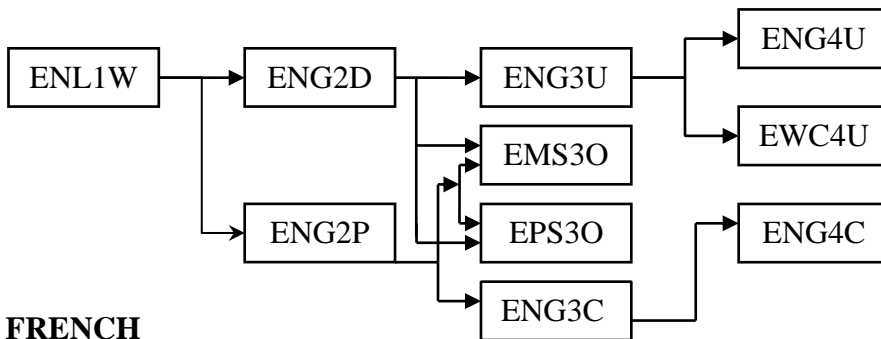

### FRENCH

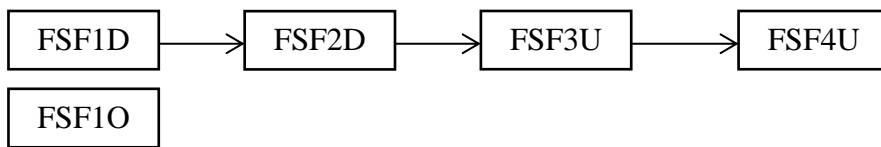

\*\* In order to provide more opportunities for strong French students in grade 9 and 10 to improve their French skills, we now offer a section of Grade 9 Geography in the French language and a section of Grade 10 History in the French language using French language resources.

## Mathematics Program

Mathematical systems were imagined and constructed by people but the possibility of mathematics was created by God and is a reflection of His order and sovereignty in the universe. Humans have the joyful task to understand mathematical processes and part of that task is to develop theories and to use them in practical ways. At its best, mathematics is a window on the majesty of God, allowing us to glimpse the Creator at work and to marvel at His creativity.

The mathematics program at Redeemer has two emphases. The initial emphasis is on the thorough development of the students' understanding of the technical and theoretical aspects of mathematics. With this understanding they will have the background to use mathematics to solve real problems. In so doing, students will develop skills in reasoning, thought processing, communication and problem solving, all of which are important in other areas of life and academic work. Students will also become acquainted with the great mathematicians and the basis for various numbering and mathematical systems.

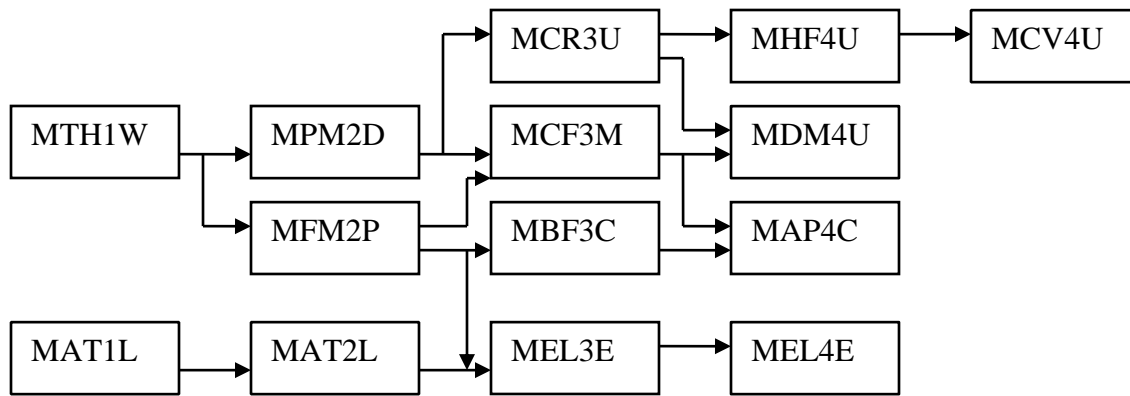

## Physical Education Program

The Health and Physical Education Program at Redeemer Christian High School sees God as the source of life. The command He gives to us, to “love the Lord your God with all your heart and with all your soul and with all your mind and with all your strength,” appeals to every aspect of our human being. The Health and Physical Education program promotes this through healthy active living, as well as enjoyment and regular, enthusiastic participation in physical activity. The courses help students understand how their personal actions and decisions will affect their health, fitness, and well-being, as well as their ability to serve God and others. All courses in this curriculum address relevant health issues and provide students with a wide variety of activities that promote fitness, the development of living skills, and personal competence.



---

## Science Program

---

Scientific study of the natural world allows students to develop a deeper understanding of God’s complex creation. While discovering the beauty, diversity and complexity of creation, students will recognize God’s majesty and His perfect design, drawing students nearer to their Creator. Fundamentally we would like students to develop a theology of creation in which they learn to read the creation as one form of God’s word to us. We live in a culture dominated by the ideas and applications of scientific principles and discoveries, generally on the basis of the assumption that science is value-free and essentially utilitarian in nature. While scientific study will help students to better understand scientific concepts, they will also be challenged to react to the concepts and paradigms they encounter on the basis of their own ethical and intellectual principles. It is important for students to appreciate science and the joys of living in a society which applies scientific principles to our stewardship of the earth. They also need to know the double-edged nature of scientific discovery as we view some of the dreadful applications of science which have so compromised life on this earth.

### SCIENCE

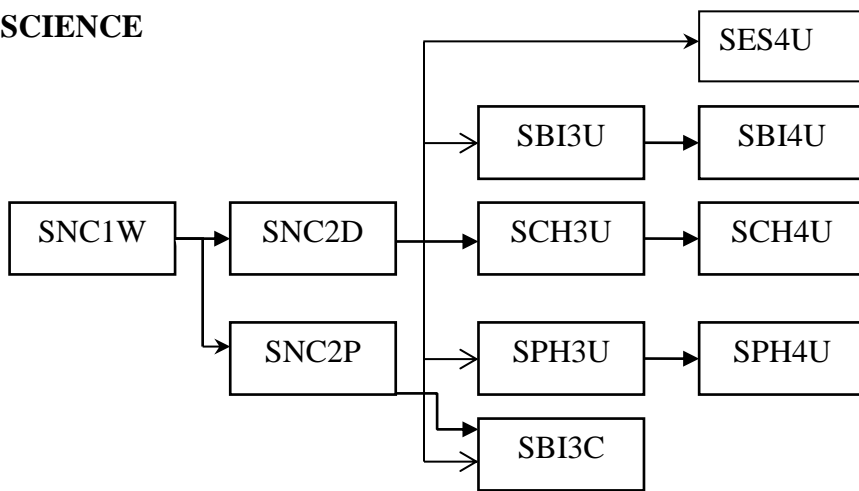

**Social Studies Program**

The courses in this department include studies in history, business, geography, religion, careers, civics, sociology, psychology, anthropology and world issues. The unifying theme for the department can be summarized in the phrase, "God's plan and human response". The central idea is that all human activity is a response to God's invitation to humanity to partner with Him to develop the earth for His glory and the well being of all created reality. In this study, we celebrate amazing human achievements throughout history, we grieve the reality of sin and its horrific effects on the earth and we pledge ourselves to become healers and restorers of the earth. This department is committed to exploring ways in which we can become more effective ambassadors for Christ in a beautiful and broken world.

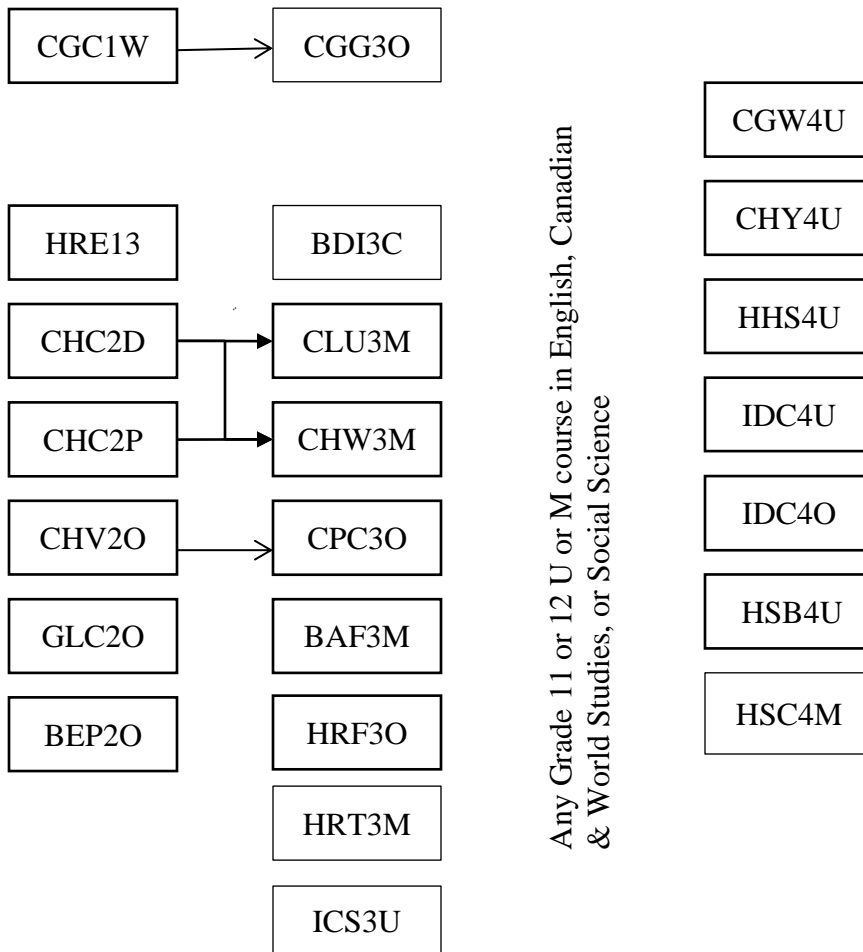

---

## Technology Program

---

Technology is a broad term referring to all the ways in which people have extended their powers as they “exercise dominion” over the earth. At Redeemer we wish to explore the important technologies of our culture, study the philosophical and historical contexts of the technologies and create opportunities for our students to develop beginning mastery of the technologies in their world.

The technologies in our culture are impressive, extending our mental and physical powers to an extent unmatched by cultures in the past or in other parts of our present world. Our technologies allow us to create a level of comfort, safety and convenience unheard of in other times and places. They also allow us to damage the creation and our fellow human being so a curious mixture of guilt and shame, along with celebration is often associated with our use of technology. Some examples are our use of power systems, genetic manipulation and medical technologies which are used to extend, enhance, and end life. Some members of our culture place an undue level of confidence in technology to solve the world’s problems suggesting a religious confidence more appropriately invested in God and His enduring principles for life.

At Redeemer we explore the historical, social and religious context in which technologies are developed and used. We want our students to have the skills to evaluate all technologies on their merits and not assume that all technologies are value-neutral, or that they necessarily represent positive developments. We need to explore the truth that our technologies are the result of human choices on the basis of a world view, and that they have both good and evil results for the earth and its people. To summarize, we want our students to develop Biblical discernment in the area of technology.

TAS10

TTJ3C

TWJ3E



**Course Selection Worksheet**

In order to assist students in planning their high school program, we have provided the worksheet below. Students, with the help of their parents, are encouraged to plan as far ahead as possible to ensure that all course/program prerequisites are met.

| Grade 9 | Grade 10                                  |
|---------|---|
|         | prerequisite met <input type="checkbox"/> |
|         | prerequisite met <input type="checkbox"/> |
|         | prerequisite met <input type="checkbox"/> |
|         | prerequisite met <input type="checkbox"/> |
|         | prerequisite met <input type="checkbox"/> |
|         | prerequisite met <input type="checkbox"/> |
|         | prerequisite met <input type="checkbox"/> |
|         | prerequisite met <input type="checkbox"/> |

**CREDITS TOWARD MY SECONDARY SCHOOL DIPLOMA**

**Compulsory Credits**

- |   |  |
|---|--|
| <input type="checkbox"/> <input type="checkbox"/> <input type="checkbox"/> English<br><input type="checkbox"/> Mathematics 9-10<br><input type="checkbox"/> Mathematics 11 or 12<br><input type="checkbox"/> Science<br><input type="checkbox"/> French as a Second Language<br><input type="checkbox"/> Canadian History | <input type="checkbox"/> Canadian Geography<br><input type="checkbox"/> The Arts<br><input type="checkbox"/> Health and Physical Education<br><input type="checkbox"/> Civics (.5 of a credit)<br><input type="checkbox"/> Career Studies (.5 of a credit) |
|---|--|



**Course Selection Worksheet**

| University/College Program | Prerequisites Needed |  |
|----------------------------|----------------------|--|
|                            |                      |  |
|                            |                      |  |

| Grade 11                                  | Grade 12                                  |
|---|---|
| prerequisite met <input type="checkbox"/> | prerequisite met <input type="checkbox"/> |
| prerequisite met <input type="checkbox"/> | prerequisite met <input type="checkbox"/> |
| prerequisite met <input type="checkbox"/> | prerequisite met <input type="checkbox"/> |
| prerequisite met <input type="checkbox"/> | prerequisite met <input type="checkbox"/> |
| prerequisite met <input type="checkbox"/> | prerequisite met <input type="checkbox"/> |
| prerequisite met <input type="checkbox"/> | prerequisite met <input type="checkbox"/> |
| prerequisite met <input type="checkbox"/> | prerequisite met <input type="checkbox"/> |
| prerequisite met <input type="checkbox"/> | prerequisite met <input type="checkbox"/> |

- One additional credit in English, or a third language, or Social Sciences and the Humanities, or Canadian and World Studies, or Guidance and Career Education, or Cooperative Education
- One additional credit in Health and Physical Education, or Business Studies or The Arts, or Cooperative Education

- One additional credit in Science (Grade 11 or 12), or Technological Education (Grade 9-12), or Cooperative Education

Optional Credits Required

□□□□□□□□□□

---

## School Calendar 2024-2025

---

| Month            | Day         | Activity  |
|------------------|-------------|---|
| <b>August</b>    | 27          | Registration Day  |
|                  |             |   |
| <b>September</b> | 2           | Labour Day  |
|                  | 3           | First day of Semester 1, 8:40 a.m.                        |
|                  |             |   |
| <b>October</b>   | 14          | Thanksgiving Monday, no school                            |
|                  | 23-25       | Christian School Teachers' Convention, PD Days, no school |
|                  |             |   |
| <b>November</b>  | 1           | Grade 8 Day   |
|                  | 4           | PD day  |
|                  | 15          | Parent-Teacher interviews                                 |
|                  |             |   |
| <b>December</b>  | 12          | Celebration of Learning                                   |
|                  | 23 - 31     | Christmas Break   |
|                  |             |   |
| <b>January</b>   | 1 - 3       | Christmas Break   |
|                  | 6           | First day back after Christmas Break                      |
|                  | 17          | Last day of semester one classes                          |
|                  | 20          | Study day, no classes                                     |
|                  | 21-28       | Semester one <b>final exams</b>                           |
|                  | 29          | First day of semester two                                 |
|                  |             |   |
| <b>February</b>  | 17          | Family Day, no school                                     |
|                  |             |   |
|                  |             |   |
| <b>March</b>     | 10 - 14     | March Break, no school                                    |
|                  |             |   |
|                  |             |   |
| <b>April</b>     | 7           | PD day  |
|                  | 17          | Parent-Teacher interviews                                 |
|                  | 18          | Good Friday, no school                                    |
|                  | 21          | Easter Monday, no school                                  |
|                  |             |   |
| <b>May</b>       | 19          | Victoria Day, no school                                   |
|                  |             |   |
|                  |             |   |
| <b>June</b>      | 10          | Last day of regular classes                               |
|                  | 11          | Study day, no classes                                     |
|                  | 12,13,16,17 | Semester two final exams                                  |
|                  | 23          | Graduation Ceremony                                       |

---

**Pattern for Alternating Year Courses**

---

Senior courses on a two-year cycle will alternate in a pattern similar to that indicated below.

| <b>Courses not offered<br/>(Sept. odd years)</b> | <b>Courses offered in 2024-25<br/>(Sept. even years)</b> |
|--|--|
| TWJ3E  | TIJ3C  |
| PPL3O  | PPL4O  |
| HSB4U/C  | HHS4U/C  |
| CLU3M  | BAF3M  |
| MDM4U  | HSC4M  |
| EPS3O  | PSK4U  |
| CHY4U/C  | EWC4U  |
| EMS3O  | ASM3O  |
|  |  |
|  |  |
|  |  |
|  |  |

---

**Daily Schedule**

---

**Monday, Tuesday, Thursday and Friday:**

|                        |               |
|------------------------|---------------|
| Home Room              | 8:40 – 8:52   |
| 1 <sup>st</sup> Period | 8:55 – 10:10  |
| 2 <sup>nd</sup> Period | 10:15 – 11:30 |
| Lunch                  | 11:30 – 12:20 |
| 3 <sup>rd</sup> Period | 12:20 – 1:35  |
| 4 <sup>th</sup> Period | 1:40 – 2:55   |

**Wednesday:**

|                        |               |
|------------------------|---------------|
| Chapel                 | 8:40 – 9:20   |
| 1 <sup>st</sup> Period | 9:25 – 10:35  |
| 2 <sup>nd</sup> Period | 10:40 – 11:50 |
| Lunch                  | 11:50 – 12:30 |
| 3 <sup>rd</sup> Period | 12:30 – 1:40  |
| 4 <sup>th</sup> Period | 1:45 – 2:55   |

# COURSE DESCRIPTIONS

For the full descriptions of these courses go to  
[www.edu.gov.on.ca/eng/curriculum/secondary/index.html](http://www.edu.gov.on.ca/eng/curriculum/secondary/index.html)

## Redeemer Christian High School Course Calendar 2024 - 2025



**Devoted to Christ  
Dedicated to Excellence  
Committed to Serve**

The courses described on the following pages are not all available every year.

---

## Descriptions and Prerequisites of Secondary Courses Offered by Redeemer

---

### ARTS PROGRAM

#### **ADA2O, Drama, Grade 10, Open**

##### **1 Credit**

This course provides opportunities for students to explore dramatic forms conventions, and techniques. Students will explore a variety of dramatic sources from various cultures and representing a range of genres. Students will use the elements of drama in creating and communicating through dramatic works. Students will assume responsibility for decisions made in the creative and collaborative processes and will reflect on their experiences.

**Prerequisite:** None

#### **ADA3O, Drama, Grade 11, Open**

##### **1 Credit**

This course requires students to engage in dramatic processes and the presentation of dramatic works, and emphasizes the application of drama skills in other contexts and opportunities. Students will interpret and present works in a variety of dramatic forms, create and script original works, and critically analyse the processes involved in producing dramatic works. Students will develop a variety of skills related to collaboration and the presentation of dramatic works.

**Prerequisite:** None

#### **ADD3O, Drama - Production, Grade 11, Open (Parts 1 and 2)**

#### **ADG3O, Drama - Acting, Grade 11, Open (Parts 1 and 2)**

##### **½ Credit**

These are half-credit courses that students who participate in the bi-yearly drama production can earn. The expectations of these courses are based on the expectations of ADA3O.

**Prerequisite:** None

#### **AME3O, Music - Small Ensemble - Worship Leading, Grade 11, Open**

##### **1 Credit**

This course develops students' musical literacy through performance and the preparation and presentation of music productions. Students will perform works at a level consistent with previous experience. Independently and collaboratively, students will use current technology and the creative and critical analysis processes to plan, produce, present, and market musical productions. Students will respond to, reflect on, and analyse music from various genres and periods, and they will develop skills transferable to other aspects of their life and their careers.

**This course may have additional fees**

**Prerequisite:** None

#### **AMI2O, Instrumental Music Band, Grade 10, Open (Part 1 and Part 2)**

##### **½ Credit**

This course will cover the same expectations as the Grade 10 Music course, AMU2O, but will focus exclusively on performance band. This is a half credit course offered each year, 2/3 days per week during the activity block at lunch time.

**Prerequisite:** None

#### **AMI3O, Instrumental Music Band, Grade 11, Open (Part 1 and Part 2)**

##### **½ Credit**

This course will cover the same expectations as the Grade 11 Music course, AMU3O, but will focus exclusively on performance band. This is a half credit course offered each year, 2/3 days per week during the activity block at lunch time. **This course has additional fees**

**Prerequisite:** None

**AMU1O, Music, Grade 9, Open**

**1 Credit**

This course emphasizes the creation and performance of music at a level consistent with previous experience and is aimed at developing technique, sensitivity, and imagination. Students will develop musical literacy skills by using the creative and critical analysis processes in composition, performance, and a range of reflective and analytical activities. Students will develop an understanding of the conventions and elements of music and of safe practices related to music and will develop a variety of skills transferable to other areas of their life. **This course has additional fees**

**Prerequisite:** None

**AMU2O, Music, Grade 10, Open**

**1 Credit**

This course emphasizes the creation and performance of music at a level consistent with previous experience. Students will develop musical literacy skills by using the creative and critical analysis processes in composition, performance, and a range of reflective and analytical activities. Students will develop their understanding of musical conventions, practices, and terminology and apply the elements of music in a range of activities. They will also explore the function of music in society with reference to the self, communities, and cultures. **This course has additional fees**

**Prerequisite:** None

**ASM3O, Media Arts, Grade 11, Open**

**1 Credit**

This course enables students to create media arts works using available and emerging technologies such as computer animation, digital imaging, video, and a variety of media. Students will explore the elements and principles of media arts, the connections between contemporary media arts works and traditional art forms, and the importance of using responsible practices when engaged in the creative process. Students will develop the skills necessary to create and interpret media art works.

**Prerequisite:** None

**AVI2O, Visual Arts, Grade 10, Open**

**1 Credit**

This course enables students to develop their skills in producing and presenting art by introducing them to new ideas, materials, and processes for artistic exploration and experimentation. Students will apply the elements and principles of design when exploring the creative process. Students will use the critical analysis process to reflect on and interpret art within a personal, contemporary, and historical context. **This course has additional fees**

**Prerequisite:** None

**AVI3M, Visual arts, Grade 11, University/College Preparation**

**1 Credit**

This course enables students to further develop their knowledge and skills in visual arts. Students will use the creative process to explore a wide range of themes through studio work that may include drawing, painting, sculpting, and printmaking, as well as the creation of collage, multimedia works, and works using emerging technologies. Students will use the critical analysis process when evaluating their own work and the work of others. The course may be delivered as a comprehensive program or through a program focused on a particular art form (e.g. photography, video, computer graphics, and information design). **This course has additional fees**

**Prerequisite:** Visual Arts, Grade 9 or 10, Open

**AVI4M, Visual Arts, Grade 12, University/College Preparation****1 Credit**

This course focuses on enabling students to refine their use of the creative process when creating and presenting two- and three-dimensional art works using a variety of traditional and emerging media and technologies. Students will use the critical analysis process to deconstruct art works and explore connections between art and society. The studio program enables students to explore a range of materials, processes, and techniques that can be applied in their own art production. Students will also make connections between various works of art in personal, contemporary, historical, and cultural contexts. **This course has additional fees**

**Prerequisite:** Visual Arts, Grade 11, University/College Preparation

**COOPERATIVE EDUCATION PROGRAM****DCO30, Creating Opportunities Through Co-op, Grade 11, Open****2 Credits (usually)**

This course consists of a learning experience connected to a community and a cooperative education curriculum focused on developing skills, knowledge, and habits of mind that will support students in their learning, including their education and career/life planning, at school and beyond, today and in the future. Within the context of their experience connected to a community, students will apply skills, knowledge, and habits of mind that will protect and promote their health, safety, and well-being and that will strengthen their inquiry, decision-making, and leadership skills. Students will create and implement a learning plan that meets their particular interests and needs, reflect on their learning, and make connections between their experience in the community and other aspects of their lives.

**Prerequisite:** None

**OR**

**Cooperative Education can be Linked to a Related Course (or Courses) \*****2 Credits (usually)**

This course consists of a learning experience connected to a community and a cooperative education curriculum that incorporates relevant expectations from the student's related course (or courses). Students will develop skills, knowledge, and habits of mind that will support them in their learning, including their education and career/life planning, at school and beyond, today and in the future. Within the context of their experience connected to a community, students will apply, extend, and refine skills and knowledge acquired in their related course or courses and will apply skills, knowledge, and habits of mind that will protect and promote their health, safety, and well-being. They will create and implement a learning plan that meets their particular interests and needs, reflect on their learning, and make connections between their experience in the community and other aspects of their lives.

**Prerequisite:** None

**SOCIAL STUDIES PROGRAM****BAF3M, Financial Accounting Fundamentals, Grade 11, University/College Preparation****1 Credit**

This course introduces students to the fundamental principles and procedures of accounting. Students will develop financial analysis and decision-making skills that will assist them in future studies and/or career opportunities in business. Students will acquire an understanding of accounting for a service and a merchandising business, computerized accounting, financial analysis, ethics and current issues in accounting.

**Prerequisite:** None

**BEP20, Launching and Leading a Business, Grade 10, Open****1 Credit**

This course introduces students to the world of business and what is required to be successful, ethical, and responsible in today's economy. Students will develop the knowledge and skills needed to be an entrepreneur who knows how to respond to local and global market opportunities. Throughout the course, students will explore and understand the responsibility of managing different functions of a business. This includes accounting, marketing, information and communication technology, financial management, human resources, and production.

**Prerequisite:** None

**BOH4M, Business Leadership: Management Fundamentals, Grade 12, University/College Preparation**

**1 Credit**

This course focuses on the development of leadership skills used in managing a successful business. Students will analyse the role of a leader in business, with a focus on decision making, management of group dynamics, workplace stress and conflict, motivation of employees, and planning. Effective business communication skills, ethics, and social responsibility are also emphasized.

**Prerequisite:** None

**CGC1W, Exploring Canadian Geography, Grade 9, De-streamed**

**1 Credit**

This course builds on learning in Grades 7 and 8 in geography. Students will explore relationships within and between Canada's natural and human systems and how they interconnect with other parts of the world. Students will examine environmental and economic issues, and their impact related to topics such as natural resources and industries, careers, land use and responsible development, and sustainability. In addition, students will understand the connections that diverse communities and individuals have with the physical environment and each other throughout Canada, including First Nations, Metis, and Inuit perspectives. Students will apply geographic thinking, use the geographic inquiry process, and use geospatial technologies throughout their investigations.

**Prerequisite:** None

**CGC1WF, Explorer la géographie du Canada, 9<sup>e</sup> année, cours décloisonné**

**1 Credit**

Ce cours s'appuie sur l'apprentissage de la 7<sup>e</sup> et de la 8<sup>e</sup> année en géographie. Dans le cours, l'élève explore les relations au sein des systèmes naturels et humains au Canada et entre ceux-ci, ainsi que les façons dont ces systèmes interagissent avec d'autres parties du monde. L'élève examine également des enjeux environnementaux et économiques, ainsi que leur incidence sur divers secteurs, y compris les ressources naturelles, les industries, les carrières, l'utilisation et l'aménagement responsable du territoire et la durabilité. De plus, l'élève explore les liens que diverses communautés et individus établissent avec l'environnement physique et entre eux partout au Canada, y compris les perspectives des Premières Nations, des Métis et des Inuits relatives à ces liens. L'élève met en application les concepts de la pensée critique en géographie et utilise le processus d'enquête et les technologies géospatiales tout au long de ses enquêtes.

**Préalable:** Aucun

**CGG3O, Travel and Tourism: A Geographic Perspective, Grade 11, Open**

**1 Credit**

This course focuses on issues related to travel and tourism within and between various regions of the world. Students will investigate unique environmental, sociocultural, economic, and political characteristics of selected world regions. They will explore travel patterns and trends, as well as tensions related to tourism, and will predict future tourism destinations. Students will apply the concepts of geographic thinking and the geographic inquiry process, including spatial technologies, to investigate the impact of the travel industry on natural environments and human communities.

**Prerequisite:** Issues in Canadian Geography, Grade 9, Academic or Applied

**CGW4C, World Issues: A Geographic Analysis, Grade 12, College Preparation**

**1 Credit**

This course explores many difficult challenges facing Canada and the world today – challenges such as unequal access to food, water, and energy; urbanization; globalization; and meeting the needs of a growing world population while ensuring the sustainability of the natural environment. Students will explore these and other world issues from environmental, social, economic, and political perspectives, while applying the concepts of geographic thinking, the geographic inquiry process, and spatial technologies to guide and support their investigations.

**Prerequisite:** Issues in Canadian Geography, Grade 9, Academic or Applied



**CGW4U, World Issues: A Geographic Analysis, Grade 12, University Preparation****1 Credit**

In this course, students will address the challenge of creating a more sustainable and equitable world. They will explore issues involving a wide range of topics, including economic disparities, threats to the environment, globalization, human rights, and quality of life, and will analyse government policies, international agreements, and individual responsibilities relating to them. Students will apply the concepts of geographic thinking and the geographic inquiry process, including the use of spatial technologies, to investigate these complex issues and their impacts on natural and human communities around the world.

**Prerequisite:** Any university or university/college preparation course in Canadian and world studies, English, or social sciences and humanities

**CHC2D, Canadian History since World War 1, Grade 10, Academic****1 Credit**

This course explores social, economic, and political developments and events and their impact on the lives of different individuals, groups, and communities, including First Nations, Métis, and Inuit individuals and communities, in Canada since 1914. Students will examine the role of conflict and cooperation in Canadian society, Canada's evolving role within the global community, and the impact of various individuals, organizations, and events on identities, citizenship, and heritage in Canada. Students will develop an understanding of some of the political developments and government policies that have had a lasting impact on First Nations, Métis, and Inuit individuals and communities. They will develop their ability to apply the concepts of historical thinking and the historical inquiry process, including the interpretation and analysis of evidence, when investigating key issues and events in Canadian history since 1914.

**Prerequisite:** None

**CHC2P, Canadian History since World War 1, Grade 10, Applied****1 Credit**

This course focuses on the social context of historical developments and events and how they have affected the lives of people in Canada, including First Nations, Métis, and Inuit individuals and communities, since 1914. Students will explore interactions between various communities in Canada as well as contributions of individuals and groups to heritage and identities in Canada. Students will develop an understanding of some key political developments and government policies that have had an impact on First Nations, Métis, and Inuit individuals and communities. They will develop their ability to apply the concepts of historical thinking and the historical inquiry process, including the interpretation and analysis of evidence, when investigating the continuing relevance of historical developments and how they have helped shape communities in present-day Canada.

**Prerequisite:** None

**CHC2PF, Histoire du Canada depuis la Première Guerre mondiale. Cours appliqué, 10e année****1 Credit**

Ce cours retrace les événements historiques qui ont le plus influé sur la vie des Canadiennes et Canadiens depuis la Première Guerre mondiale. L'élève examine les liens entre différentes communautés au Canada et les contributions de personnes et de groupes à l'identité et au patrimoine canadiens. En utilisant les concepts de la pensée critique en histoire et le processus d'enquête, ce qui inclut l'analyse et l'interprétation d'éléments de preuve, l'élève acquiert les compétences nécessaires pour mieux comprendre les changements qui ont façonné le Canada et l'Ontario français d'aujourd'hui.

**Préalable:** Aucun

### **CHV2O, Civics and Citizenship, Grade 10, Open**

#### **½ Credit**

This course explores rights and responsibilities associated with being an active citizen in a democratic society. Students will explore issues of civic importance and the influence of social media, while developing their understanding of the role of civic engagement and of political processes in the local, national, and/or global community. Students will apply the concepts of political thinking and the political inquiry process to investigate, and express informed opinions about, a range of political issues and developments that are both of significance in today's world and of personal interest to them. This course also includes learning on digital literacy and critical-thinking skills, the mechanisms of government, Indigenous governance systems and structures, the historical foundations of the rights and freedoms we enjoy in Canada, ways in which government policy affects individuals' lives and the economy, and ways for students to serve their communities.

**Prerequisite:** None

### **CHW3M, World History to the end of the Fifteenth Century, Grade 11, University/College Preparation**

#### **1 Credit**

This course explores the history of various societies around the world, from earliest times to around 1500 CE. Students will examine life in and the legacy of various ancient and pre-modern societies throughout the world, including those in, Africa, Asia, Europe, and the Americas. Students will extend their ability to apply the concepts of historical thinking and the historical inquiry process, including the interpretation and analysis of evidence, when investigating social, political, and economic structures and historical forces at work in various societies and in different historical eras.

**Prerequisite:** Canadian History since World War I, Grade 10, Academic or Applied

Tracing, in particular, the histories of Mediterranean civilizations, students study the contexts in which Christian worldviews and culture developed. This cultivates an historical background in which to discover the significance of biblical events and early church development. Through this history, students are witnesses to (and participants in) the ongoing conversation God's people must have with the societies they find themselves in. This prepares Redeemer students to explore the power of ideas and spiritual commitments more fully in IDC4O/IDC4U.

### **CHY4C, World History since the Fifteenth Century, Grade 12, College Preparation**

#### **1 Credit**

This course explores key developments and events in world history since approximately 1450, with a focus on interactions within and between various regions. Students will examine social, economic, and political developments and how they have affected different peoples. Students will extend their ability to apply the concepts of historical thinking and the historical inquiry process, including the interpretation and analysis of evidence, when investigating key turning points in world history and historical forces that have shaped our world.

**Prerequisite:** Any university, university/college, or college preparation course in Canadian and world studies, English, or social sciences and humanities

### **CHY4U, World History since the Fifteenth Century, Grade 12, University Preparation**

#### **1 Credit**

This course traces major developments and events in world history since approximately 1450. Students will explore social, economic, and political changes, the historical roots of contemporary issues, and the role of conflict and cooperation in global interrelationships. They will extend their ability to apply the concepts of historical thinking and the historical inquiry process, including the interpretation and analysis of evidence, as they investigate key issues and assess societal progress or decline in world history.

**Prerequisite:** Any university or university/college preparation course in Canadian and world studies, English, or social sciences and humanities.

**CLU3M, Understanding Canadian Law, Grade 11, University/ College Preparation****1 Credit**

This course explores Canadian law, with a focus on legal issues that are relevant to the lives of people in Canada. Students will gain an understanding of laws relating to rights and freedoms in Canada; our legal system; and family, contract, employment, tort, and criminal law. Students will develop legal reasoning skills and will apply the concepts of legal thinking and the legal studies inquiry process when investigating a range of legal issues and formulating and communicating informed opinions about them.

**Prerequisite:** Canadian History since World War I, Grade 10, Academic or Applied

**CPC3O, Politics in Action: Making Change, Grade 11, Open****1 Credit**

This course enables students to develop plans for change in the local, national, and/or global community. Students will explore various issues, investigating their causes as well as their impact, and determining where change is needed, and why. They will examine the effectiveness of various problem-solving strategies used by individuals and groups that have brought about and/or are attempting to bring about political change in democratic societies. In addition, students will analyse the role and perspectives of governments and other stakeholders in relation to issues of political importance and will consider factors affecting their own and others' political engagement. Students will apply the concepts of political thinking and the political inquiry process as they investigate various issues of political importance and develop a plan of action to address a selected issue.

**Prerequisite:** Civics and Citizenship, Grade 10, Open

**GLC2O, Career Studies, Grade 10, Open****½ Credit**

This course gives students the opportunity to develop the skills, knowledge, and habits that will support them in their education and career/life planning. Students will learn about global work trends and seek opportunities within the school and community to expand and strengthen their transferable skills and their ability to adapt to the changing world of work. Based on exploration, reflective practice, and decision-making processes, students will make connections between their skills, interests, and values and their postsecondary options, whether in apprenticeship training, college, community living, university, or the workplace. They will set goals and create a plan for their first postsecondary year. As part of their preparation for the future, they will learn about personal financial management – including the variety of saving and borrowing tools available to them and how to use them to their advantage – and develop a budget for their first year after secondary school.

**Prerequisite:** None

**HFA4C, Nutrition and Health, Grade 12, College Preparation****1 Credit**

This course focuses on the relationship between nutrition and health at different stages of life and on global issues related to food production. Students will investigate the role of nutrition in health and disease and assess strategies for promoting food security and environmental responsibility. Students will learn about healthy eating, expand their repertoire of food-preparation techniques, and refine their ability to use social science research and inquiry methods to investigate topics related to nutrition and health.

**Prerequisite:** Any university, college, or university/college preparation course in social sciences and humanities, English, or Canadian and world studies

**HFA4U, Nutrition and Health, Grade 12, University Preparation****1 Credit**

This course examines the relationships between food, energy balance, and nutritional status; the nutritional needs of individuals at different stages of life; and the role of nutrition in health and disease. Students will evaluate nutrition-related trends and will determine how food choices can promote food security and environmental responsibility. Students will learn about healthy eating, expand their repertoire of food-preparation techniques, and develop their social science research skills by investigating issues related to nutrition and health.

**Prerequisite:** Any university or university/college preparation course in social sciences and humanities, English, or Canadian and world studies

### **HHS4C, Families in Canada, Grade 12, College Preparation**

#### **1 Credit**

This course enables students to develop an understanding of social science theories as they apply to individual development, the development of intimate relationships, and family and parent-child relationships. Students will explore a range of issues relating to the development of individuals and families in contemporary Canadian society as well as in other cultures and historical periods. They will develop the investigative skills required to conduct research on individuals, intimate relationships, and parent-child roles and relationships in Canada.

**Prerequisite:** Any university, college, or university/college preparation course in social sciences and humanities, English, or Canadian and world studies.

### **HHS4U, Families in Canada, Grade 12, University Preparation**

#### **1 Credit**

This course enables students to draw on sociological, psychological, and anthropological theories and research to analyze the development of individuals, intimate relationships, and family and parent-child relationships. Students will focus on issues and challenges facing individuals and families in Canada's diverse society. They will develop analytical tools that enable them to assess various factors affecting families and to consider policies and practices intended to support families in Canada. They will develop the investigative skills required to conduct and communicate the results of research on individuals, intimate relationships, and parent-child relationships.

**Prerequisite:** Any university or university/college preparation course in social sciences and humanities, English, or Canadian and world studies.

### **HRE13, New Testament, Grade 9, Open**

#### **1 Credit**

After a summary of the historical and social setting between the Old and New Testaments, students examine the gospel of Matthew to discover connections between the Old Testament and the person of Jesus. Context and content are examined for the book of Acts, three of Paul's letters, James and Revelation. A summary of the origins and devotional uses of New Testament texts completes the course.

**Prerequisite:** None

### **HRF3O, World Religions and Belief Traditions in Daily Life, Grade 11, Open**

#### **1 Credit**

This course enables students to study world religions and belief traditions in local, Canadian, and global contexts. Students will explore aspects of the human quest for meaning and will examine world religions and belief traditions as exemplified in various sacred teachings and principles, rites, and passages. They will also study the interaction throughout history between society and various belief traditions, and will have opportunities to develop research and inquiry skills related to the study of world religions and belief traditions.

**Prerequisite:** None

### **HRT3M, World Religions and Belief Traditions: Perspectives, Issues, and Challenges, Grade 11, University/College Preparation**

#### **1 Credit**

This course provides students with opportunities to explore various world religions and belief traditions. Students will develop knowledge of the terms and concepts relevant to this area of study, will examine the ways in which religions and belief traditions meet various human needs, and will learn about the relationship between belief and action. They will examine sacred writings and teachings, consider how concepts of time and place influence different religions and belief traditions, and develop research and inquiry skills related to the study of human expressions of belief.

**Prerequisite:** None

**HSB4U, Challenge and Change in Society, Grade 12, University Preparation****1 Credit**

This course focuses on the use of social science theories, perspectives, and methodologies to investigate and explain shifts in knowledge, attitudes, beliefs, and behaviour and their impact on society. Students will critically analyze how and why cultural, social, and behavioural patterns change over time. They will explore the ideas of social theorists and use those ideas to analyze causes of and responses to challenges such as technological change, deviance, and global inequalities. Students will explore ways in which social science research methods can be used to study social change.

**Prerequisite:** Any university or university/college preparation course in social sciences and humanities, English, or Canadian and world studies.

**HSC4M, World Cultures, Grade 12, University/College Preparation****1 Credit**

This course examines the nature of culture; how cultural identities are acquired, maintained, and transformed; and theories used to analyse cultures. Students will explore world cultures, with an emphasis on the analysis of religious and spiritual beliefs, art forms, and philosophy. They will study the contributions and influence of a range of cultural groups and will critically analyse issues facing ethnocultural groups within Canada and around the world. Students will develop and apply research skills and will design and implement a social action initiative relating to cultural diversity.

**Prerequisite:** Any university, college, or university/college preparation course in social sciences and humanities, English, or Canadian and world studies.

**ICS3U, Introduction to Computer Science, Grade 11, University Preparation****1 Credit**

This course introduces students to computer science. Students will design software independently and as part of a team, using industry-standard programming tools and applying the software development life-cycle model. They will also write and use subprograms within computer programs. Students will develop creative solutions for various types of problems as their understanding of the computing environment grows. They will also explore environmental and ergonomic issues, emerging research in computer science, and global career trends in computer-related fields.

**Prerequisite:** None

This course examines some topics in Computer Science, including computer hardware and software, social and ethical issues related to computer technology, and coding. The coding segment is the largest component of this course and will focus on the fundamentals of programming, using text-based problems. Strong problem solving and paying close attention to detail are skills that will be strengthened with this course. Although we will not be developing graphical or video game applications, this course will prepare students for future courses of this type.

**IDC4O, Interdisciplinary Studies Senior Seminar; Faith and Culture: Where Faith Meets Life Grade 12, Open****1 Credit**

This course emphasizes the development of practical skills and knowledge to solve problems, make decisions, create personal meaning, and present findings beyond the scope of a single subject or discipline. Through individual and collaborative inquiry and research into contemporary issues, real-life situations, and careers, students will apply the principles and skills derived from the complementary subjects and disciplines studied, evaluate the reliability of information, and examine how information technology can be used safely, effectively and legally. They will also learn how to select strategies to define problems, research alternative solutions, assess their thinking in reaching decisions, and adapt to change as they acquire new knowledge.

Ideas shape our world in a host of explicit and implicit ways. In order for our students to develop the discernment associated with a mature Christian mind, Redeemer has created this opportunity to explore the philosophical and religious depth of a variety of aspects of their world. This course is designed to be a culminating study in which students will have the opportunity to reflect on their experience using the material and expectations from a number of courses. The course is designed around the great philosophical questions which people have asked throughout the ages and gives students opportunities to explore answers expressed in a variety of practical settings and situations. Through this exercise, students will have opportunities to deepen their wisdom with their exploration occurring in the context of Biblical reflection.

**Prerequisite:** None

**IDC4U, Interdisciplinary Studies Senior Seminar; Faith and Culture: Where Faith Meets Life, Grade 12, University Preparation**

**1 Credit**

This course will help students develop and consolidate the skills required for and knowledge of different subjects and disciplines to solve problems, make decisions, create personal meaning, and present findings beyond the scope of a single subject or discipline. Students will apply the principles and processes of inquiry and research to effectively use a range of print, electronic and mass media resources, to analyze historical innovations and exemplary research; and to investigate real-life situations and career opportunities in interdisciplinary endeavours. They will also assess their own cognitive and affective strategies, apply general skills in both familiar and new contexts, create innovative products and communicate new knowledge.

This course is designed to help our students become more aware of the philosophical presuppositions of the ideas driving our world and of the implications of those ideas in a variety of intellectual and practical fields. In this interdisciplinary course, students will explore the social, artistic, political, economic and ethical expressions of philosophical presuppositions and frameworks. They will reflect critically on these expressions, especially focusing on the faith perspective. They will develop their own responses, rooted in the application of a Christian worldview based on Biblical principles. Under the guidance of an experienced teacher, students will also explore ways in which spiritual powers and principalities shape our communal and individual lives. They will gain understanding of Christianity as a relevant cultural force with a long tradition of positive cultural engagement which provides an alternative of hope in a world searching for its spiritual roots.

**Prerequisite:** Any university or university/college preparation course

**LANGUAGES**

**EMS30, Media Studies, Grade 11, Open**

**1 Credit**

This course emphasizes the knowledge and skills that will enable students to understand media communication in the twenty-first century and to use media effectively and responsibly. Through analysing the forms and messages of a variety of media works and audience responses to them, and through creating their own media works, students will develop critical thinking skills, aesthetic and ethical judgement, and skills in viewing, representing, listening, speaking, reading, and writing.

**Prerequisite:** English, Grade 10, Academic or Applied

**ENG2D, English, Grade 10, Academic**

**1 Credit**

This course is designed to extend the range of oral communication, reading, writing, and media literacy skills that students need for success in their secondary school academic programs and in their daily lives. Students will analyze literary texts from contemporary and historical periods, interpret and evaluate informational and graphic texts, and create oral, written, and media texts in a variety of forms. An important focus will be on the selective use of strategies that contribute to effective communication. This course is intended to prepare students for the compulsory Grade 11 university or college preparation course.

**Prerequisite:** English, Grade 9, Academic or Applied

**ENG2P, English, Grade 10, Applied**

**1 Credit**

This course is designed to extend the range of oral communication, reading, writing, and media literacy skills that students need for success in secondary school and daily life. Students will study and create a variety of informational, literary, and graphic texts. An important focus will be on the consolidation of strategies and processes that help students interpret texts and communicate clearly and effectively. This course is intended to prepare students for the compulsory Grade 11 college or workplace preparation course.

**Prerequisite:** English, Grade 9, Academic or Applied

**ENG3C, English, Grade 11, College Preparation****1 Credit**

This course emphasizes the development of literacy, communication and critical and creative thinking skills necessary for success in academic and daily life. Students will study the content, form, and style of a variety of informational and graphic texts as well as literary texts from Canada and other countries, and create oral, written, and media texts in a variety of forms for practical and academic purposes. An important focus will be on using language with precision and clarity. The course is intended to prepare students for the compulsory Grade 12 college preparation course.

**Prerequisite:** English, Grade 10, Applied

**ENG3U, English, Grade 11, University Preparation****1 Credit**

This course emphasizes the development of literacy, communication, and critical and creative thinking skills necessary for success in academic and daily life. Students will analyze challenging literary texts from various periods, countries, and cultures, as well as a range of informational and graphic texts, and create oral, written, and media texts in a variety of forms. An important focus will be on using language with precision and clarity and incorporating stylistic devices appropriately and effectively. The course is intended to prepare students for the compulsory Grade 12 university or college preparation course.

**Prerequisite:** English, Grade 10, Academic

**ENG4C, English, Grade 12, College Preparation****1 Credit**

This course emphasizes the consolidation of literacy, communication, and critical and creative thinking skills necessary for success in academic and daily life. Students will analyse a variety of informational and graphic texts, as well as literary texts from various countries and cultures, and create oral, written, and media texts in a variety of forms for practical and academic purposes. An important focus will be on using language with precision and clarity and developing greater control in writing. The course is intended to prepare students for college or the workplace.

**Prerequisite:** English, Grade 11, College Preparation

**ENG4U, English, Grade 12, University Preparation****1 Credit**

This course emphasizes the consolidation of the literacy, communication, and critical and creative thinking skills necessary for success in academic and daily life. Students will analyse a range of challenging literary texts from various periods, countries, and cultures; interpret and evaluate informational and graphic texts; and create oral, written, and media texts in a variety of forms. An important focus will be on using academic language coherently and confidently, selecting the reading strategies best suited to particular texts and particular purposes for reading, and developing greater control in writing. The course is intended to prepare students for university, college, or the workplace.

**Prerequisite:** English, Grade 11, University Preparation

**ENL1W, English, Grade 9****1 Credit**

This course enables students to continue to develop and consolidate the foundational knowledge and skills that they need for reading, writing, and oral and visual communication. Throughout the course, students will continue to enhance their media literacy and critical literacy skills, and to develop and apply transferable skill, including digital literacy. Students will also make connections to their lived experiences and to society and increase their understanding of the importance of language and literacy across the curriculum.

**Prerequisite:** None

**EPS3O, Presentation and Speaking Skills, Grade 11, Open**

**1 Credit**

This course emphasizes the knowledge and skills required to plan and make effective presentations and to speak effectively in both formal and informal contexts, using such forms as reports, speeches, debates, panel discussions, storytelling, recitations, interviews, and multimedia presentations. Students will research and analyse the content and characteristics of convincing speeches and the techniques of effective speakers; design and rehearse presentations for a variety of purposes and audiences; select and use visual and technological aids to enhance their message; and assess the effectiveness of their own and others' presentations.

**Prerequisite:** English, Grade 10, Academic or Applied

**EWC4U, The Writer's Craft, Grade 12, University Preparation**

**1 Credit**

This course emphasizes knowledge and skills related to the craft of writing. Students will analyze models of effective writing; use a workshop approach to produce a range of works; identify and use techniques required for specialized forms of writing; and identify effective ways to improve the quality of their writing. They will also complete a major paper as part of a creative or analytical independent study project and investigate opportunities for publication and for writing careers.

**Prerequisite:** English, Grade 11, University Preparation

**FSF1D, Core French, Grade 9, Academic**

**1 Credit**

This course provides opportunities for students to communicate and interact in French with increasing independence, with a focus on familiar topics related to their daily lives. Students will develop their skills in listening, speaking, reading, and writing by using language learning strategies introduced in the elementary Core French program, and will apply creative and critical thinking skills in various ways. They will also enhance their understanding and appreciation of diverse French-speaking communities and will develop skills necessary for lifelong language learning.

**Prerequisite:** Minimum of 600 hours of French instruction, or equivalent

**FSF1O, Core French, Grade 9, Open**

**1 Credit**

This is an introductory course for students who have little or no knowledge of French or who have not accumulated the minimum of 600 hours of elementary Core French instruction. Students will begin to understand and speak French in guided and structured interactive settings, and will develop fundamental skills in listening, speaking, reading, and writing through discussing issues and situations that are relevant to their daily lives. Throughout the course, students will develop their awareness of diverse French-speaking communities in Canada and acquire an understanding and appreciation of these communities. They will also develop a variety of skills necessary for lifelong language learning.

**Prerequisite:** None

**FSF2D, Core French, Grade 10, Academic**

**1 Credit**

This course provides opportunities for students to communicate in French about personally relevant, familiar, and academic topics in real-life situations with increasing independence. Students will exchange information, ideas, and opinions with others in guided and increasingly spontaneous spoken interactions. Students will develop their skills in listening, speaking, reading, and writing through the selective use of strategies that contribute to effective communication. They will also increase their understanding and appreciation of diverse French-speaking communities and will develop skills necessary for lifelong language learning.

**Prerequisite:** Core French, Grade 9, Academic or Applied



**FSF3U, Core French, Grade 11, University Preparation****1 Credit**

This course offers students extended opportunities to speak and interact in real-life situations in French with greater independence. Students will develop their listening, speaking, reading, and writing skills, as well as their creative and critical thinking skills, through responding to and exploring a variety of oral and written texts. They will also broaden their understanding and appreciation of diverse French-speaking communities and will develop skills necessary for lifelong language learning.

**Prerequisite:** Core French, Grade 10, Academic

**FSF4U, Core French, Grade 12, University Preparation****1 Credit**

This course provides extensive opportunities for students to speak and interact in French independently. Students will develop their listening, speaking, reading, and writing skills, apply language learning strategies in a wide variety of real-life situations, and develop their creative and critical thinking skills through responding to and interacting with a variety of oral and written texts. They will also enrich their understanding and appreciation of diverse French-speaking communities and will develop skills necessary for lifelong language learning.

**Prerequisite:** Core French, Grade 11, University Preparation

**MATHEMATICS PROGRAM****MAP4C, Foundations for College Mathematics, Grade 12, College Preparation****1 Credit**

This course enables students to broaden their understanding of real-world applications of mathematics. Students will analyze data using statistical methods; solve problems involving the applications of geometry and trigonometry; simplify expressions; solve financial problems connected with annuities, budgets, and renting or owning accommodation; simplify expressions; and solve equations. Students will reason mathematically and communicate their thinking as they solve multi-step problems. This course prepares students for college programs in areas such as business, health sciences, and human services, and for certain skilled trades.

**Prerequisite:** (MBF3C) Foundations for College Mathematics, Grade 11, College Preparation, or (MCF3M) Functions and Applications, Grade 11, University/College Preparation

**MBF3C, Foundations for College Mathematics, Grade 11, College Preparation****1 Credit**

This course enables students to broaden their understanding of mathematics as a problem-solving tool in the real world. Students will extend their understanding of quadratic relations, investigate situations involving exponential growth; solve problems involving compound interest; solve financial problems connected with vehicle ownership; develop their ability to reason by collecting, analysing, and evaluating data involving one variable; connect probability and statistics; and solve problems in geometry and trigonometry. Students will consolidate their mathematical skills as they solve problems and communicate their thinking.

**Prerequisite:** MFM2P, Foundations of Mathematics, Grade 10, Applied

**MCF3M, Functions and Applications, Grade 11, University/College Preparation****1 Credit**

This course introduces basic features of the function by extending students' experiences with quadratic relations. It focuses on quadratic, trigonometric, and exponential functions and their use in modelling real-world situations. Students will represent functions numerically, graphically, and algebraically; simplify expressions; solve equations; and solve problems relating to applications. Students will reason mathematically and communicate their thinking as they solve multi-step problems.

**Prerequisite:** MPM2D, Principles of Mathematics, Grade 10, Academic, or MFM2P, Foundations of Mathematics, Grade 10, Applied

### **MCR3U, Functions, Grade 11, University Preparation**

#### **1 Credit**

This course introduces the mathematical concept of the function by extending students' experiences with linear and quadratic relations. Students will investigate properties of discrete and continuous functions, including trigonometric and exponential functions; represent functions numerically, algebraically, and graphically; solve problems involving applications of functions; investigate inverse functions; and develop facility in determining equivalent algebraic expressions. Students will reason mathematically and communicate their thinking as they solve multi-step problems.

**Prerequisite:** MPM2D, Principles of Mathematics, Grade 10, Academic

### **MCV4U, Calculus and Vectors, Grade 12, University Preparation**

#### **1 Credit**

This course builds on students' previous experience with functions and their developing understanding of rates of change. Students will solve problems involving geometric and algebraic representations of vectors and representations of lines and planes in three-dimensional space; broaden their understanding of rates of change to include the derivatives of polynomial, sinusoidal, exponential, rational, and radical functions; and apply these concepts and skills to the modelling of real-world relationships. Students will also refine their use of the mathematical processes necessary for success in senior mathematics. This course is intended for students who choose to pursue careers in fields such as science, engineering, economics, and some areas of business, including those students who will be required to take a university-level calculus, linear algebra, or physics course.

**Prerequisite:** Advanced Functions (MHF4U) must be taken prior to or concurrently with Calculus and Vectors (MCV4U).

### **MDM4U, Mathematics of Data Management, Grade 12, University Preparation**

#### **1 Credit**

This course broadens students' understanding of mathematics as it relates to managing data. Students will apply methods for organizing and analysing large amounts of information; solve problems involving probability and statistics; and carry out a culminating project that integrates statistical concepts and skills. Students will also refine their use of the mathematical processes necessary for success in senior mathematics. Students planning to enter university programs in business, the social sciences, and the humanities will find this course of particular interest.

**Prerequisite:** MCF3M, Functions and Applications, Grade 11, University/College Preparation, or MCR3U, Functions, Grade 11, University Preparation

### **MEL3E, Mathematics for Work and Everyday Life, Grade 11, Workplace Preparation**

#### **1 Credit**

This course enables students to broaden their understanding of mathematics as it is applied in the workplace and daily life. Students will solve problems associated with earning money, paying taxes and making purchases; apply calculations of simple and compound interest in saving, investing and borrowing; and calculate the costs of transportation and travel in a variety of situations. Students will consolidate their mathematical skills as they solve problems and communicate their thinking.

**Prerequisite:** MPM1D, Principles of Mathematics, Grade 9, Academic or MFM1P, Foundations of Mathematics, Grade 9, Applied or MAT2L, Essentials of Mathematics, Grade 10, Locally Developed

### **MEL4E, Mathematics for Work and Everyday Life, Grade 12, Workplace Preparation**

#### **1 Credit**

This course enables students to broaden their understanding of mathematics as it is applied in the workplace and daily life. Students will investigate questions involving the use of statistics; apply the concepts of probability to solve problems involving familiar situations; investigate accommodation costs, create household budgets, and prepare a personal income tax return; use proportional reasoning; estimate and measure; and apply geometric concepts to create designs. Students will consolidate their mathematical skills as they solve problems and communicate their thinking.

**Prerequisite:** MEL3E, Mathematics for Work and Everyday Life, Grade 11, Workplace Preparation

**MFM2P, Foundations of Mathematics, Grade 10, Applied****1 Credit**

This course enables students to consolidate their understanding of linear relations and extend their problem-solving and algebraic skills through investigation, the effective use of technology, and hands-on activities. Students will develop and graph equations in analytic geometry; solve and apply linear systems, using real life examples; and explore and interpret graphs of quadratic relations. Students will investigate similar triangles, the trigonometry of right triangles, and the measurement of three-dimensional figures. Students will consolidate their mathematical skills as they solve problems and communicate their thinking.

**Prerequisite:** MPM1D, Principles of Mathematics, Grade 9, Academic or MFM1P, Foundations of Mathematics, Grade 9, Applied

**MHF4U, Advanced Functions, Grade 12, University Preparation****1 Credit**

This course extends students' experience with functions. Students will investigate the properties of polynomial, rational, logarithmic, and trigonometric functions; develop techniques for combining functions; broaden their understanding of rates of change; and develop facility in applying these concepts and skills. Students will also refine their use of the mathematical processes necessary for success in senior mathematics. This course is intended both for students taking the Calculus and Vectors course as a prerequisite for a university program and for those wishing to consolidate their understanding of mathematics before proceeding to any one of a variety of university programs.

**Prerequisite:** MCR3U, Functions, Grade 11, University Preparation, or MCT4C, Mathematics for College Technology, Grade 12, College Preparation

**MPM2D, Principles of Mathematics, Grade 10, Academic****1 Credit**

This course enables students to broaden their understanding of relationships and extend their problem-solving and algebraic skills through investigation, the effective use of technology, and abstract reasoning. Students will explore quadratic relations and their applications; solve and apply linear systems; verify properties of geometric figures using analytic geometry; and investigate the trigonometry of right and acute triangles. Students will reason mathematically and communicate their thinking as they solve multi-step problems.

**Prerequisite:** MPM1D, Principles of Mathematics, Grade 9, Academic

**MTH1W, Mathematics, Grade 9****1 Credit**

This course enables students to consolidate, and continue to develop, an understanding of mathematical concepts related to number sense and operations, algebra, measurement, geometry, data, probability, and financial literacy. Students will use mathematical processes, mathematical modelling, and coding to make sense of the mathematics they are learning and to apply their understanding to culturally responsive and relevant real-world situations. Students will continue to enhance their mathematical reasoning skills, including proportional reasoning, spatial reasoning, and algebraic reasoning, as they solve problems and communicate their thinking.

**Prerequisite:** None

**PHYSICAL AND HEALTH EDUCATION PROGRAM****PLF4M, Recreation and Healthy Active Living Leadership, Grade 12, University/College Preparation****1 Credit**

This course enables students to explore the benefits of lifelong participation in active recreation and healthy leisure and to develop the leadership and coordinating skills needed to plan, organize, and safely implement recreational events and other activities related to healthy, active living. Students will also learn how to promote the benefits of healthy, active living to others through mentoring and assisting them in making informed decisions that enhance their well-being. The course will prepare students for university programs in physical education and health and kinesiology and for college and university programs in recreation and leisure management, fitness and health promotion, and fitness leadership.

**Prerequisite:** Any health and physical education course

**PPL10, Healthy Active Living Education, Grade 9, Open**

**1 Credit**

This course equips students with the knowledge and skills they need to make healthy choices now and lead healthy, active lives in the future. Through participation in a wide range of physical activities, students develop knowledge and skills related to movement competence and personal fitness that provide a foundation for active living. Students also acquire an understanding of the factors and skills that contribute to healthy development and learn how their own well-being is affected by, and affects, the world around them. Students build their sense of self, learn to interact positively with others, and develop their ability to think critically and creatively.

**Prerequisite:** None

**PPL20 Healthy Active Living Education, Grade 10, Open**

**1 Credit**

This course enables students to further develop the knowledge and skills they need to make healthy choices now and lead healthy, active lives in the future. Through participation in a wide range of physical activities, students develop knowledge and skills related to movement competence and personal fitness that provide a foundation for active living. Students also acquire an understanding of the factors and skills that contribute to healthy development and learn how their own well-being is affected by, and affects, the world around them. Students build their sense of self, learn to interact positively with others, and develop their ability to think critically and creatively.

**Prerequisite:** None

**PPL30, Healthy Active Living Education, Grade 11, Open**

**1 Credit**

This course enables students to further develop the knowledge and skills they need to make healthy choices now and lead healthy, active lives in the future. Through participation in a wide range of physical activities and exposure to a broader range of activity settings, students enhance their movement competence, personal fitness, and confidence. Students also acquire an understanding of the factors and skills that contribute to healthy development and learn how their own well-being is affected by, and affects, the world around them. Students build their sense of self, learn to interact positively with others, and develop their ability to think critically and creatively.

**Prerequisite:** None

**PPL40, Healthy Active Living Education, Grade 12, Open**

**1 Credit**

This course enables students to further develop the knowledge and skills they need to make healthy choices. It places special emphasis on how students can maintain the habits of healthy, active living throughout their lives as they make the transition to adulthood and independent living. Through participation in a wide range of physical activities in a variety of settings, students can enhance their movement competence, personal fitness, and confidence. Students also acquire an understanding of the factors and skills that contribute to healthy development and learn how their own well-being is affected by, and affects, the world around them. Students build their sense of self, learn to interact positively with others, and develop their ability to think critically and creatively.

**Prerequisite:** None

**PSK4U, Introductory Kinesiology, Grade 12, University Preparation**

**1 Credit**

This course focuses on the study of human movement and of systems, factors, and principles involved in human development. Students will learn about the effects of physical activity on health and performance, the evolution of physical activity and sport, and the physiological, psychological, and social factors that influence an individual's participation in physical activity and sport. The course prepares students for university programs in physical education and health, kinesiology, health sciences, health studies, recreation, and sports administration.

**Prerequisite:** Any Grade 11 university or university/college preparation course in science, or any Grade 11 or 12 course in health and physical education

**SCIENCE PROGRAM****SBI3C, Biology, Grade 11, College Preparation****1 Credit**

This course focuses on the processes that occur in biological systems. Students will learn concepts and theories as they conduct investigations in the areas of cellular biology, microbiology, genetics, the anatomy of mammals, and the structure of plants and their role in the natural environment. Emphasis will be placed on the practical application of concepts, and on the skills needed for further study in various branches of the life sciences and related fields.

**Prerequisite:** SNC2D, Science, Grade 10, Academic or SNC2P, Science, Grade 10, Applied

**SBI3U, Biology, Grade 11, Academic****1 Credit**

This course furthers students' understanding of the processes that occur in biological systems. Students will study theory and conduct investigations in the areas of biodiversity; evolution; genetic processes; the structure and function of animals; and the anatomy, growth and functions of plants. The course focuses on the theoretical aspects of the topics under study, and helps students refine skills related to scientific investigation.

**Prerequisite:** SNC2D, Science, Grade 10, Academic

**SBI4U, Biology, Grade 12, University Preparation****1 Credit**

This course provides students with the opportunity for in-depth study of the concepts and processes that occur in biological systems. Students will study theory and conduct investigations in the areas of biochemistry, metabolic processes, molecular genetics, homeostasis, and population dynamics. Emphasis will be placed on achievement of the detailed knowledge and refinement of skills needed for further study in various branches of the life sciences and related fields.

**Prerequisite:** SBI3U, Biology, Grade 11, University Preparation

**SCH3U, Chemistry, Grade 11, University Preparation****1 Credit**

This course enables students to deepen their understanding of chemistry through the study of the properties of chemicals and chemical bonds; chemical reactions and quantitative relationships in those reactions; solutions and solubility; and atmospheric chemistry and the behaviour of gases. Students will further develop their analytical skills and investigate the qualitative and quantitative properties of the matter, as well as the impact of some common chemical reactions on society and the environment.

**Prerequisite:** SNC2D, Science, Grade 10, Academic

**SCH4C, Chemistry, Grade 12, College Preparation****1 Credit**

This course enables students to develop an understanding of chemistry through the study of matter and qualitative analysis, organic chemistry, electrochemistry, chemical calculations, and chemistry as it relates to the quality of the environment. Students will use a variety of laboratory techniques, develop skills in data collection and scientific analysis, and communicate scientific information using appropriate terminology. Emphasis will be placed on the role of chemistry in daily life and the effects of technological applications and processes on society and the environment.

**Prerequisite:** Science, Grade 10, Academic or Applied

**SCH4U, Chemistry, Grade 12, University Preparation****1 Credit**

This course enables students to deepen their understanding of chemistry through the study of organic chemistry, the structure and properties of matter, energy changes and rates of reaction, equilibrium in chemical systems, and electrochemistry. Students will further develop their problem-solving and investigative skills as they investigate chemical processes and will refine their ability to communicate scientific information. Emphasis will be placed on the importance of chemistry in everyday life and on evaluating the impact of chemical technology on the environment.

**Prerequisite:** SCH3U, Chemistry, Grade 11, University Preparation

### **SNC1W, Science, Grade 9**

#### **1 Credit**

This course enables students to develop their understanding of concepts related to biology, chemistry, physics, and earth and space science, and to relate science to technology, society, and the environment. Throughout the course, students will develop and refine their STEM skills as they use scientific research, scientific experimentation, and engineering design processes to investigate concepts and apply their knowledge in situations that are relevant to their lives and communities. Students will continue to develop transferable skills as they become scientifically literate global citizens.

**Prerequisite:** None

### **SNC2D, Science, Grade 10, Academic**

#### **1 Credit**

This course enables students to enhance their understanding of concepts in biology, chemistry, earth and space science, and physics, and of the interrelationships between science, technology, society, and the environment. Students are also given opportunities to further develop their scientific investigations skills. Students will plan and conduct investigations and develop their understanding of scientific theories related to the connections between cells and systems in animals and plants; chemical reactions, with a particular focus on acid-base reactions; forces that affect climate and climate change; and the interaction of light and matter.

**Prerequisite:** SNC1D, Science, Grade 9, Academic or SNC1P, Science, Grade 9, Applied

### **SNC2P, Science, Grade 10, Applied**

#### **1 Credit**

This course enables students to develop a deeper understanding of concepts in biology, chemistry, earth and space science, and physics; and to apply their knowledge of science in real-world situations. Students are given opportunities to develop further practical skills in scientific investigation. Students will plan and conduct investigations into everyday problems and issues related to human cells and body systems; chemical reactions; factors affecting climate change; and the interaction of light and matter.

**Prerequisite:** SNC1D, Science, Grade 9, Academic or SNC1P, Science, Grade 9, Applied

### **SPH3U, Physics, Grade 11, University Preparation**

#### **1 Credit**

This course develops students' understanding of the basic concepts of physics. Students will explore kinematics, with an emphasis on linear motion; different kinds of forces; energy transformations; the properties of mechanical waves and sound; and electricity and magnetism. They will enhance their scientific investigation skills as they test laws of physics. In addition, they will also analyse the interrelationships between physics and technology, and consider the impact of technological applications of physics on society and the environment.

**Prerequisite:** SNC2D, Science, Grade 10, Academic

### **SPH4U, Physics, Grade 12, University Preparation**

#### **1 Credit**

This course enables students to deepen their understanding of physics concepts and theories. Students will continue their exploration of energy transformations and the forces that affect motion, and will investigate electrical, gravitational, and magnetic fields and electromagnetic radiation. Students will also explore the wave nature of light, quantum mechanics, and special relativity. They will further develop their scientific investigations skills, learning, for example, how to analyse, qualitatively and quantitatively, data relating to a variety of physics concepts and principles. Students will also consider the impact of technological applications of physics on society and the environment.

**Prerequisite:** SPH3U, Physics, Grade 11, University Preparation

**TECHNOLOGY PROGRAM****TAS1O, Technology and the Skilled Trades, Grade 9, Open****1 Credit**

This hands-on course enables students to further explore the engineering design process and develop other technological knowledge and skills introduced in earlier grades. Students will design and safely create prototypes, products, and/or services, working with tools and technologies from various industries. As students develop their projects to address real-life problems, they will apply technological concepts such as precision measurement, as well as health and safety standards. Students will begin to explore job skills programs and education and training pathways, including skilled trades that can lead to a variety of careers.

**Prerequisite:** None

**TAS2O, Technology and the Skilled Trades, Grade 10, Open****1 Credit**

This hands-on course enables students to apply the engineering design process and other technological knowledge and skills introduced in earlier grades. Students will design and safely create prototypes, products, and/or services, working with tools and resources from various industries. As students develop their projects to address real-life problems, they will apply technological concepts such as quality control, and health and safety standards. Students explore opportunities for job skills programs and education and training pathways, including skilled trades, that can lead to a variety of careers.

**Prerequisite:** None

**TTJ3C, Transportation Technology, Grade 11, College Preparation****1 Credit**

This course enables students to develop technical knowledge and skills as they study, test, service, and repair engine, electrical, suspension, brake, and steering systems on vehicles, aircraft, and/or watercraft. Students will develop communication and teamwork skills through practical tasks, using a variety of tools and equipment. Students will develop an awareness of environmental and societal issues related to transportation, and will learn about apprenticeship and college programs leading to careers in the transportation industry.

**Prerequisite:** None

**TWJ3E, Custom Woodworking, Grade 11, Workplace****1 Credit**

This course enables students to develop knowledge and skills related to cabinet making and furniture making. Students will gain practical experience using a variety of the materials, tools, equipment, and joinery techniques associated with custom woodworking. Students will learn to create and interpret technical drawings and will plan, design, and fabricate projects. They will also develop an awareness of environmental and societal issues related to the woodworking industry, and will explore apprenticeships, postsecondary training, and career opportunities in the field that may be pursued directly after graduation.

**Prerequisite:** None

**Course Codes and Titles Index**

|  |    |
|--|----|
| ADA2O, Dramatic Arts   | 57 |
| ADA3O, Dramatic Arts   | 57 |
| ADD3O, Drama - Production  | 57 |
| ADG3O, Drama - Acting  | 57 |
| AMI2O, Instrumental Music, Band  | 57 |
| AMI3O, Instrumental Music, Band (Part 1 and Part 2)  | 57 |
| AMU1O, Music   | 58 |
| AMU2O, Music   | 58 |
| ASM3O, Media Arts  | 58 |
| AVI2O, Visual Arts   | 58 |
| AVI3M, Visual Arts   | 58 |
| AVI4M, Visual Arts   | 59 |
| DCO3O, Creating Opportunities Through Co-op<br>Co-operative Education Program              | 59 |
| BAF3M, Financial Accounting Fundamentals   | 59 |
| BEP2O, Launching and Leading a Business  | 59 |
| BOH4M, Business Leadership: Management Fundamentals  | 60 |
| CGC1W, Exploring Canadian Geography  | 60 |
| CGC1WF, Explorer la géographie du Canada   | 60 |
| CGG3O, Travel and Tourism: A Geographic Perspective  | 60 |
| CGW4C, World Issues: A Geographic Analysis   | 60 |
| CGW4U, World Issues: A Geographic Analysis   | 61 |
| CHC2D, Canadian History Since World War 1  | 61 |
| CHC2P, Canadian History Since World War 1  | 61 |
| CHC2PF, Histoire du Canada depuis la Première Guerre mondiale                              | 61 |
| CHV2O, Civics and Citizenship  | 61 |
| CHW3M, World History to the End of the Fifteenth Century                                   | 62 |
| CHY4C, World History since the Fifteenth Century   | 62 |
| CHY4U, World History since the Fifteenth Century   | 62 |
| CLU3M, Understanding Canadian Law  | 62 |
| CPC3O, Politics in Action: Making Change   | 62 |
| GLC2O, Career Studies  | 63 |
| HFA4C, Nutrition and Health  | 63 |
| HFA4U, Nutrition and Health  | 63 |
| HHS4C, Families in Canada  | 63 |
| HHS4U, Families in Canada  | 64 |
| HRE13, Bible: New Testament  | 64 |
| HRF3O, World Religions and Belief Traditions in Daily Life                                 | 64 |
| HRT3M, World Religions and Belief Traditions: Perspectives, Issues and Challenges          | 65 |
| HSB4U, Challenge and Change in Society   | 65 |
| HSC4M, World Cultures  | 65 |
| ICS3U, Introduction to Computer Science  | 65 |
| IDC4O, Interdisciplinary Senior Seminar; Faith and Culture: Where Faith Meets Life Seminar | 65 |
| IDC4U, Interdisciplinary Senior Seminar; Faith and Culture: Where Faith Meets Life Seminar | 66 |
| EMS3O, Media Studies   | 66 |
| ENG2D, English   | 66 |
| ENG2P, English   | 66 |
| ENG3C, English   | 67 |
| ENG3U, English   | 67 |
| ENG4C, English   | 67 |
| ENG4U, English   | 67 |
| ENL1W, English   | 67 |



|  |    |
|--|----|
| EPS3O, Presentation and Speaking Skills                | 68 |
| EWC4U, The Writer's Craft                              | 68 |
| FSF1D, Core French                                     | 68 |
| FSF1O, Core French                                     | 68 |
| FSF2D, Core French                                     | 68 |
| FSF3U, Core French                                     | 69 |
| FSF4U, Core French                                     | 69 |
| MAP4C, Foundations for College Mathematics             | 69 |
| MBF3C, Foundations for College Mathematics             | 69 |
| MCF3M, Functions and Applications                      | 69 |
| MCR3U, Functions                                       | 70 |
| MCV4U, Calculus and Vectors                            | 70 |
| MDM4U, Mathematics of Data Management                  | 70 |
| MEL3E, Mathematics for Work and Everyday Life          | 70 |
| MEL4E, Mathematics for Work and Everyday Life          | 70 |
| MF2P, Foundations of Mathematics                       | 71 |
| MHF4U, Advanced Functions                              | 71 |
| MPM2D, Principles of Mathematics                       | 71 |
| MTH1W, Mathematics                                     | 71 |
| PLF4M, Recreation and Healthy Active Living Leadership | 71 |
| PPL1O, Healthy Active Living Education                 | 72 |
| PPL2O, Healthy Active Living Education                 | 72 |
| PPL3O, Healthy Active Living Education                 | 72 |
| PPL4O, Healthy Active Living Education                 | 72 |
| PSK4U, Introductory Kinesiology                        | 72 |
| SBI3C, Biology   | 73 |
| SBI3U, Biology   | 73 |
| SBI4U, Biology   | 73 |
| SCH3U, Chemistry                                       | 73 |
| SCH4C, Chemistry                                       | 73 |
| SCH4U, Chemistry                                       | 73 |
| SNC1W, Science   | 74 |
| SNC2D, Science   | 74 |
| SNC2P, Science   | 74 |
| SPH3U, Physics   | 74 |
| SPH4U, Physics   | 74 |
| TAS1O, Technology and the Skilled Trades               | 75 |
| TAS2O, Technology and the Skilled Trades               | 75 |
| TTJ3C, Transportation Technology                       | 75 |
| TWJ3E, Custom Woodworking                              | 75 |